

INTRODUCTION

This document gives a detailed summary of the new features and modifications of FEM-Design version 10.0. We hope you will enjoy using the program and its new tools and possibilities. We wish you success.

Strusoft, the developers

Legend



Pay attention / Note



Useful hint



Example



Clicking left mouse button



Clicking right mouse button



Clicking middle mouse button

Text Italic words marked in cyan are linked to their definition.

Table of content

INTRODUCTION.....	1
1 PERFORMANCE	4
2 WORKING ENVIRONMENT.....	4
2.1 User interface	4
2.2 Edit and Modify functions	7
2.3 Guide lines and Tracker	12
2.4 UCS.....	16
3 STRUCTURAL DATA.....	17
3.1 Datum.....	17
3.1.1 Axis	17
3.1.2 Storey	17
3.2 Bars	18
3.2.1 Columns	19
3.2.2 Cross-sections.....	20
3.2.3 Varying cross-section.....	21
3.2.4 End conditions.....	22
3.2.5 New eccentricity options.....	22
3.2.6 Analytical model	22
3.2.7 Apex	23
3.2.8 Intermediate section	24
3.2.9 Settings for bars	24
3.3 Shells.....	24
3.3.1 Walls.....	24
3.3.2 Eccentricity	25
3.3.3 Physical extent	25
3.4 Prefabricated elements.....	26
3.4.1 Profiled panels	26
3.4.2 Timber panels	28
3.5 Supports.....	29
4 LOADS.....	29
4.1 Load generation direction	29
4.2 Load macros in 3D Structure module	29
5 DESIGN	32
5.1 RC Design.....	33
5.2 Timber Design.....	34
6 PREDESIGN	34
7 REALDWG	35

WHAT'S NEW IN FEM-DESIGN 10.0

- Profiled panels
- Bars with varying cross-section and eccentricity
- Faster data preparation for analysis
- Design check for timber bars with varying cross-section and/or curved shape
- Load macros: Snow, Wind and Deviation
- Guide lines and tracker
- Storey handling
- New type of eccentricities for bars and shells
- Structural objects implemented by analytical and physical model
- New editing tools: Divide and Join
- User interface redesigned
- UCS
- Easier definition of walls and columns
- New way to define axes
- More user-friendly cross-section library handling
- Support ID
- Predesign module can handle all Eurocodes.
- RealDWG

1 PERFORMANCE

Process of data preparation for analysis is 3-8 times faster than in version 9.0 due to new algorithms.

2 WORKING ENVIRONMENT

2.1 User interface

- Toolbar and tab icons are redesigned.

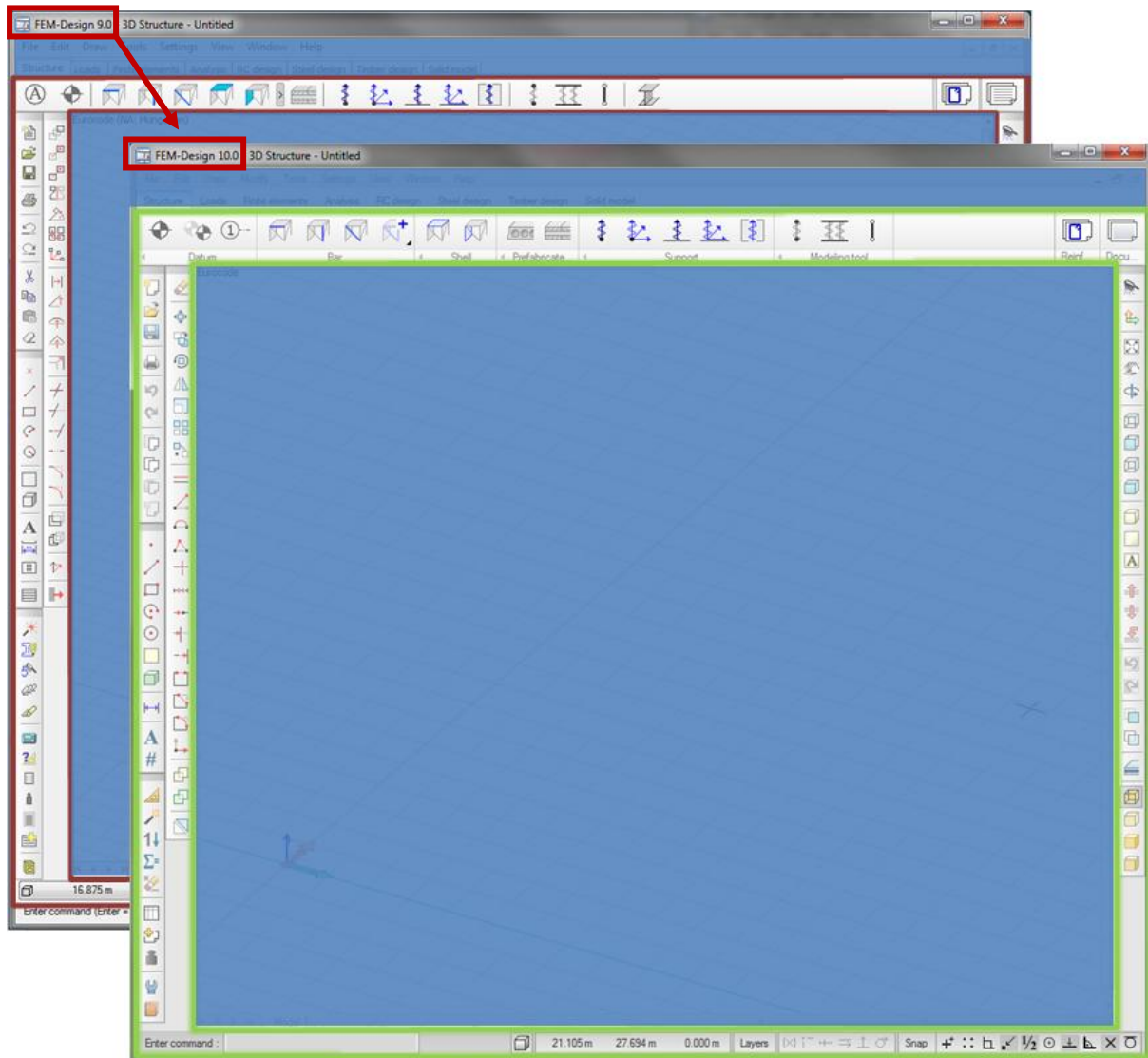

- New link to the *Settings* of objects under main commands.

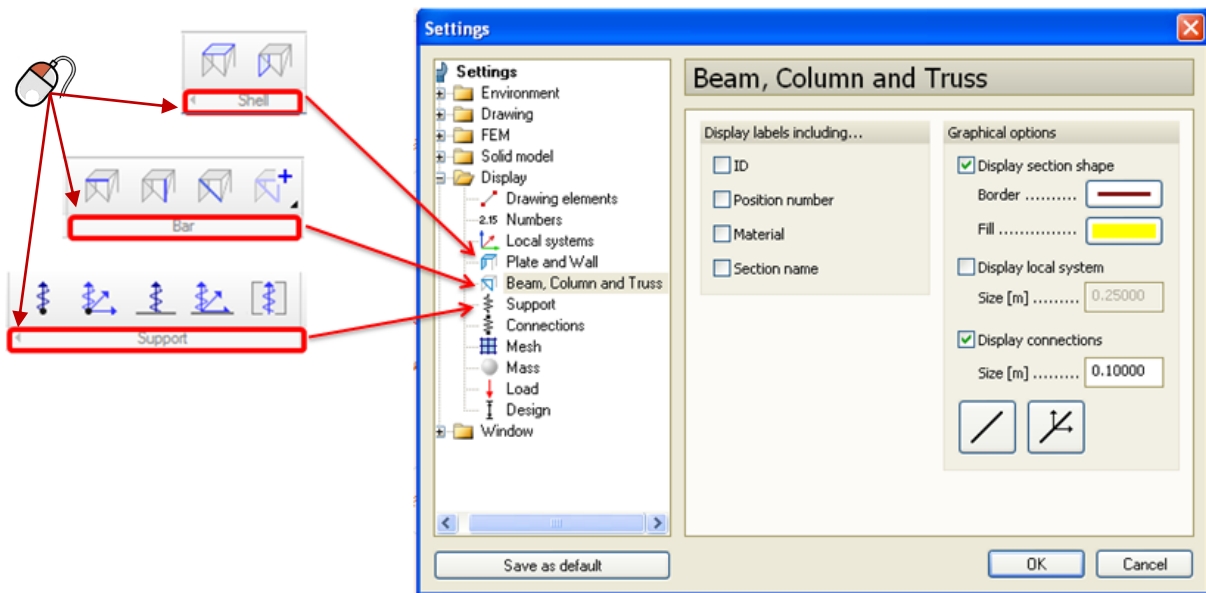

- There are a few new developments for laptop users having small screen, which are explained below.

Group of the commands in Tabs can be compacted by clicking on the ◀ sign in their lower left corner and can be expanded by clicking on the ▶ sign. If the commands are compacted, first command or last used command will be displayed. Moving the cursor over the ◀ in compacted tabs pulls down all commands.

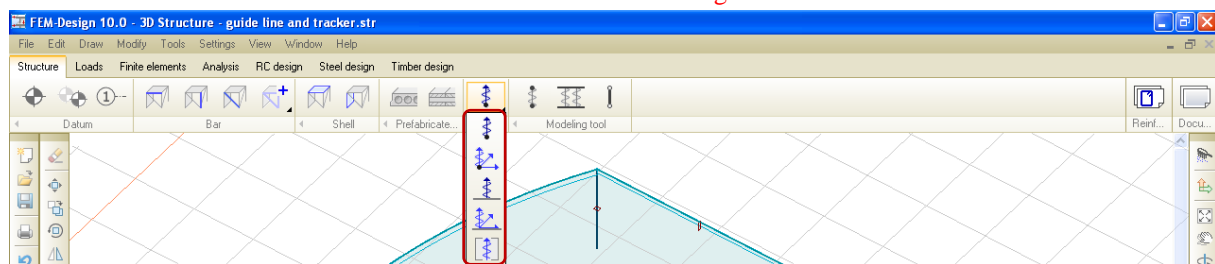
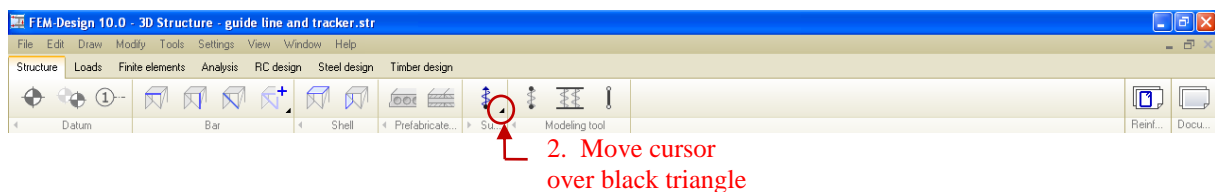
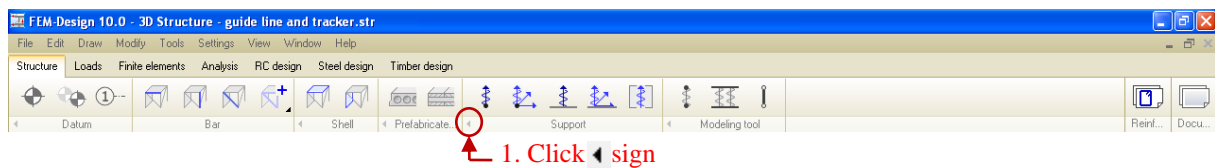

- Scrollbars made transparent. If the mouse is over them, they become opaque.

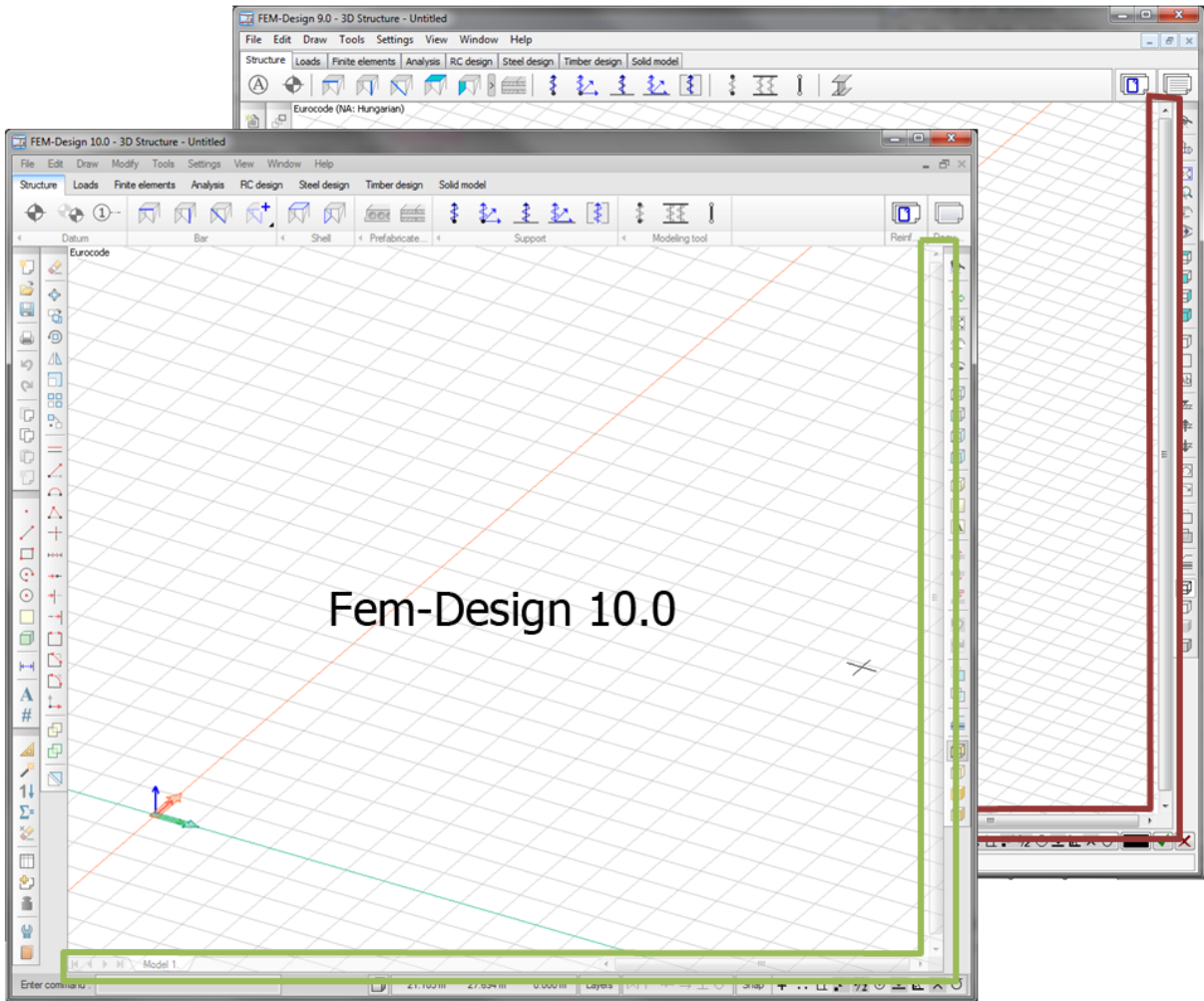

- Bottom two rows are merged into one row in order to save working space. 'Current color', 'OK' and 'Cancel' commands are removed.

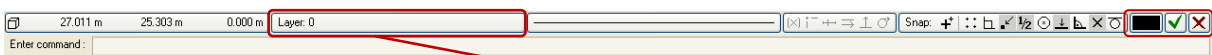

- Double  executes the 'Zoom margin' command.

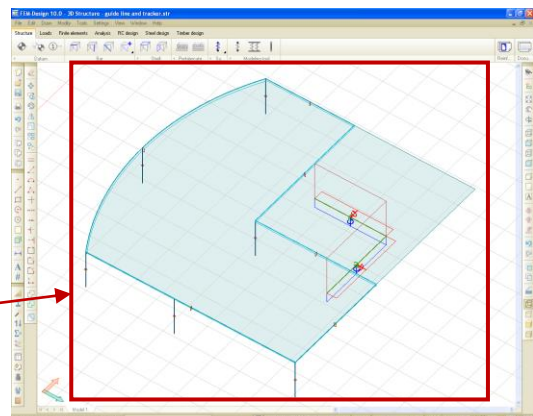
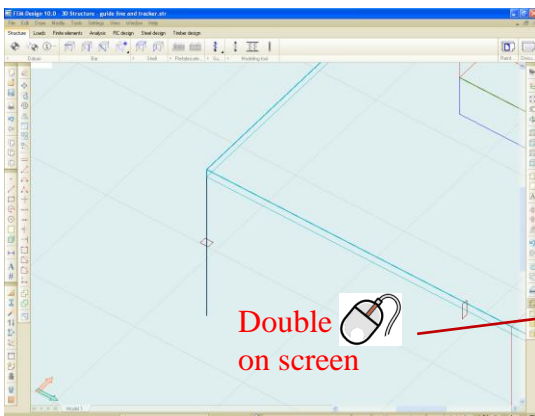

2.2 Edit and Modify functions

Edit menu is splitted into Edit and Modify.

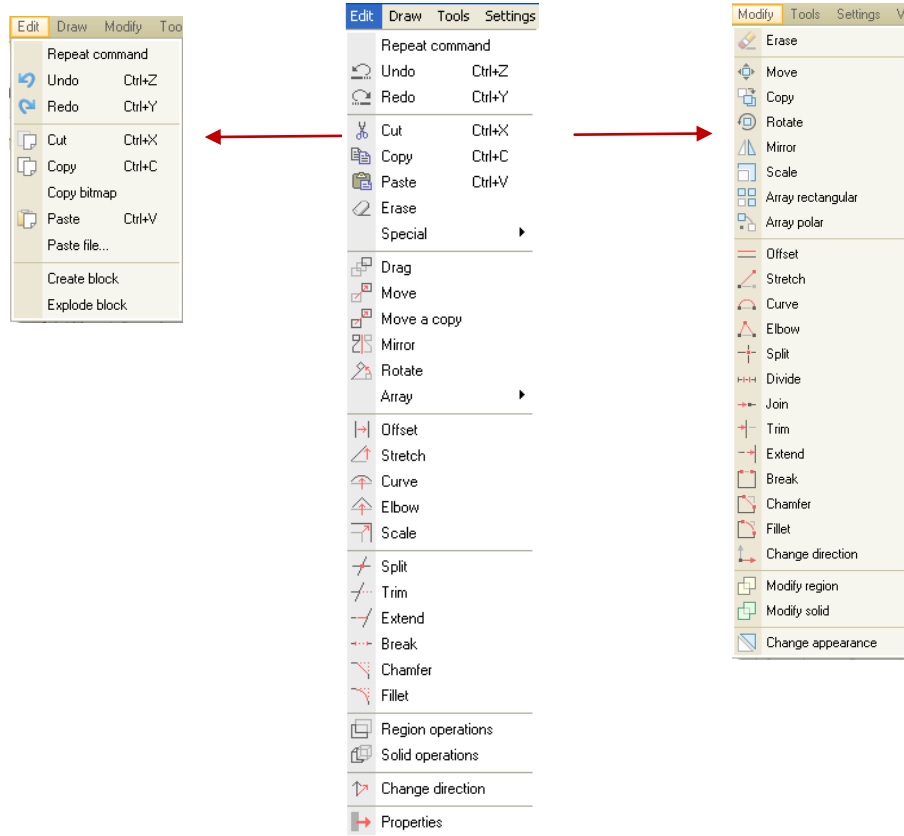

Two new modifying tools are implemented, '**Divide**' and '**Join**'.

'Divide' command splits all line elements (straight line, arc, line type elements like bars, supports, fictitious bar...) into desired number of parts.

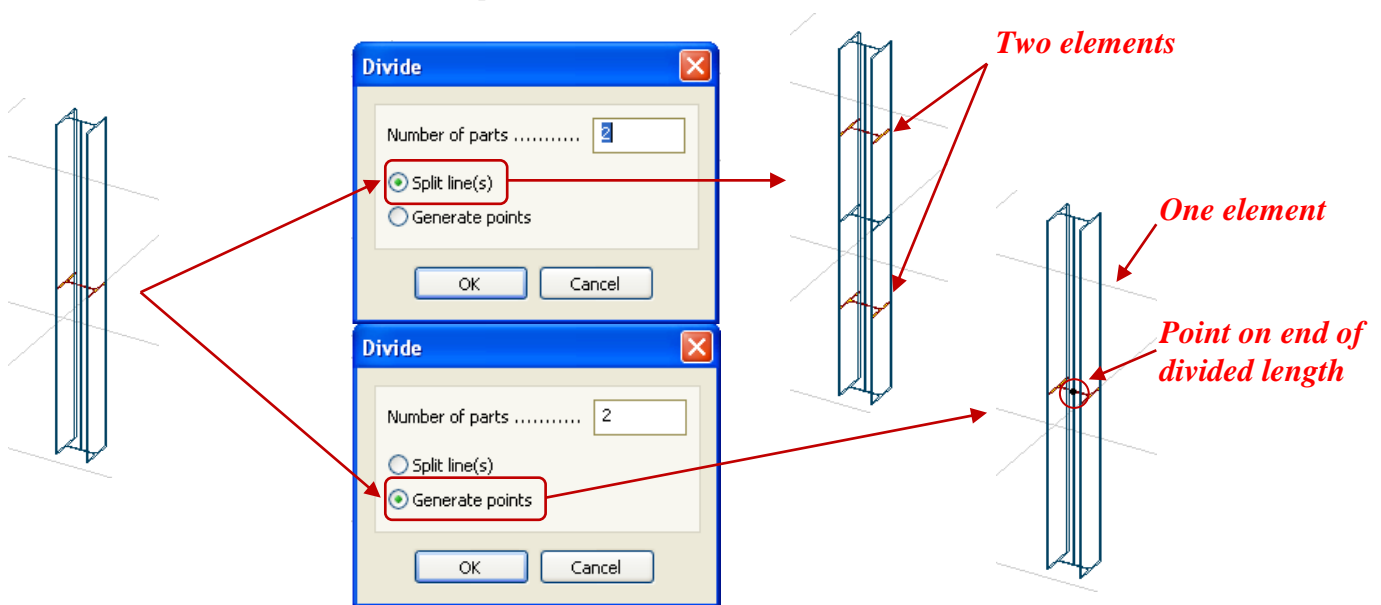

The 'Join' command merges neighboring lines, arcs and line type elements which are on the same straight line or circle.



'Divide' command will not split the truss objects, because it's interpreted by starting and ending node.

- **Quick modifications** are implemented for all elements, depending on where the cursor is standing:

	Click LB (default)	Click + hold LB	CTRL + Hold LB
Line's end point			
Node on surface edge	Stretch	Stretch	Drag a copy
Along point along line	Curve	Move	Drag a copy
Any point inside Surface	Move	Move	Drag a copy
Any point on screen, where there is nothing	Box selection		

At  user can select another command in the Modify menu which is also available by .

-  line's end point or node on surface edge starts 'Stretch' command or the last used command selected by the user for this case

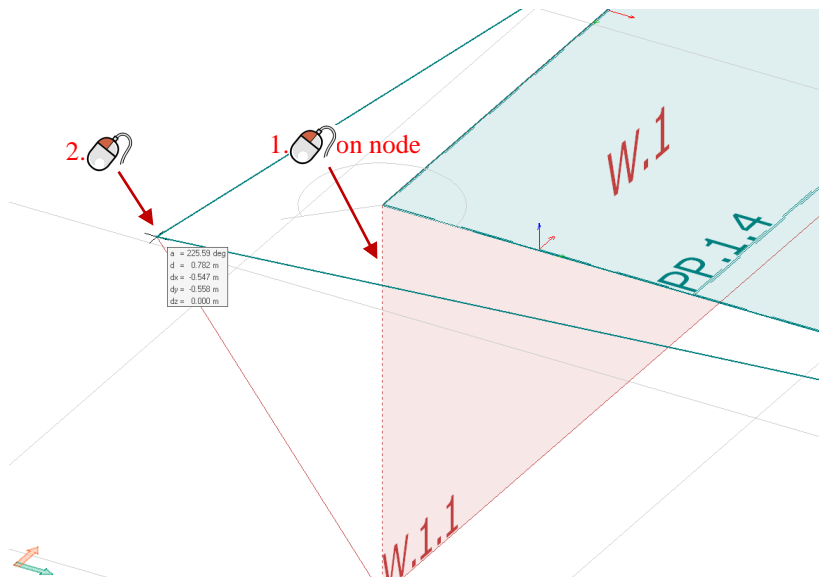

-  any point along the line starts 'Curve' command or the last command

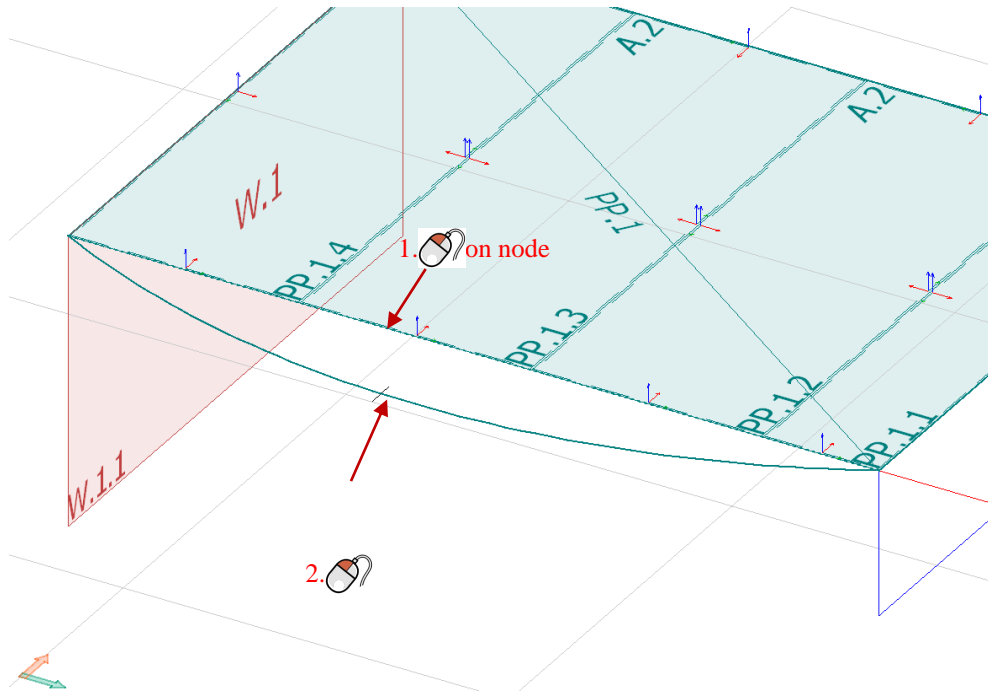

-  on any point inside on surface starts 'Move' command

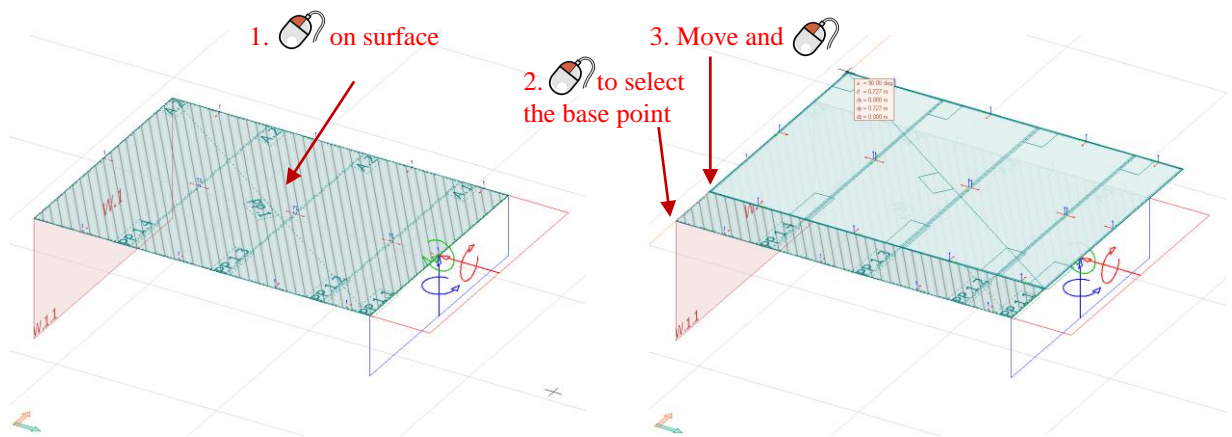

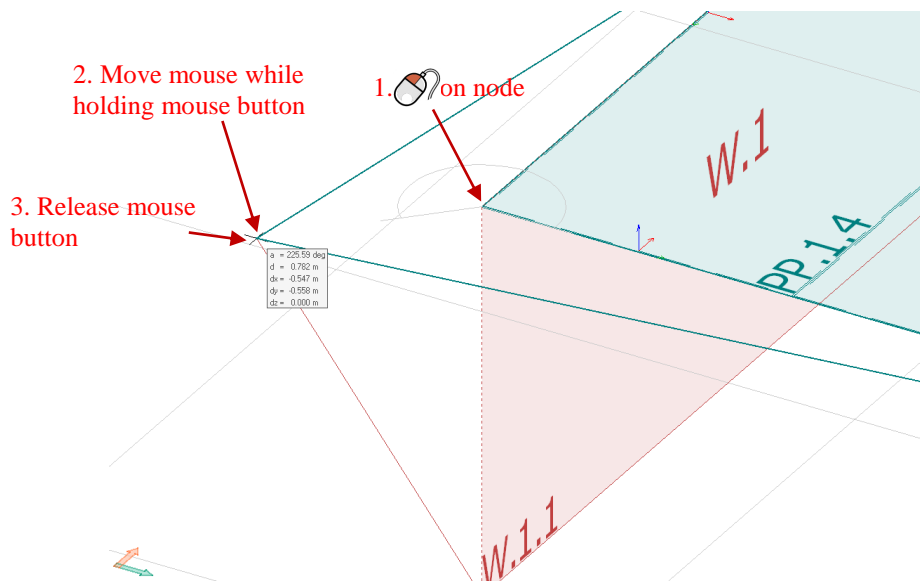

-  and holding at line's end point or surface edge's end node starts 'Stretch' command

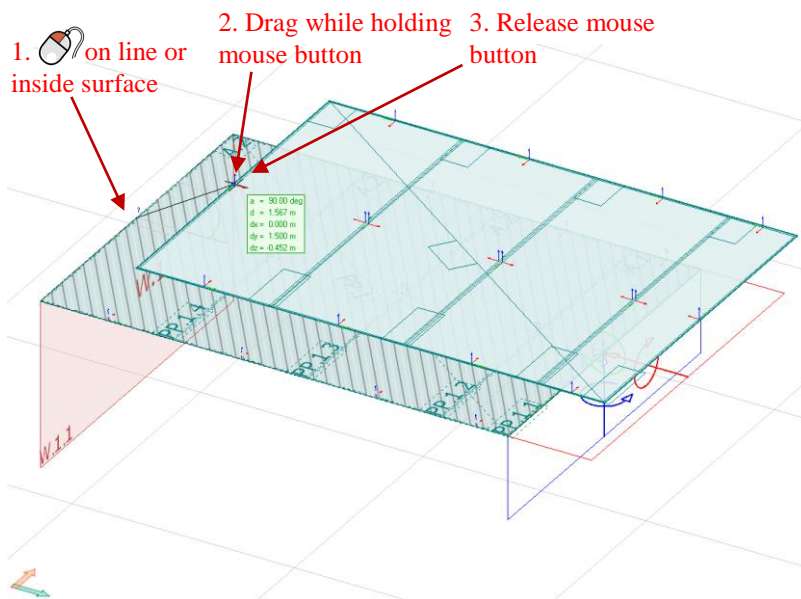

-  and holding at any point along line or any point inside surface starts 'Move' command



-  + holding  at any point in a structural or drawing element starts to drag a copy of the object.

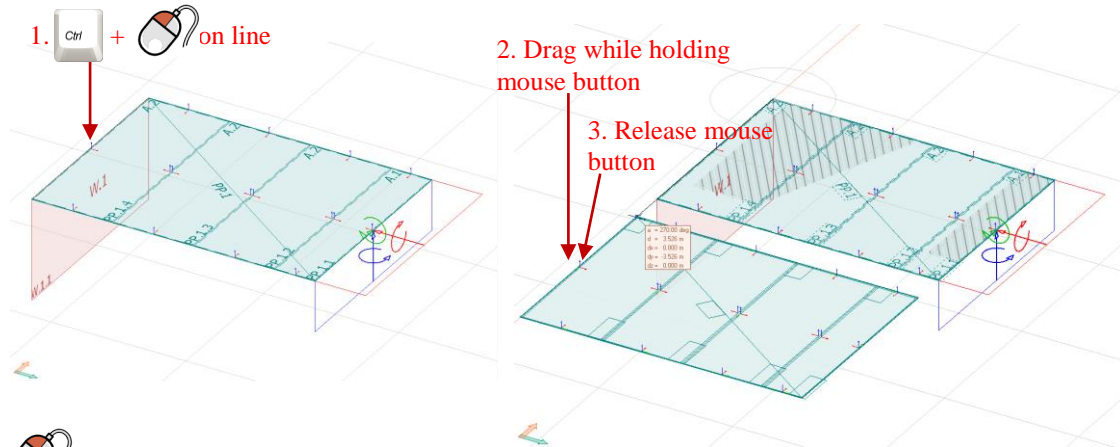

-  none of the objects starts 'Box selection'

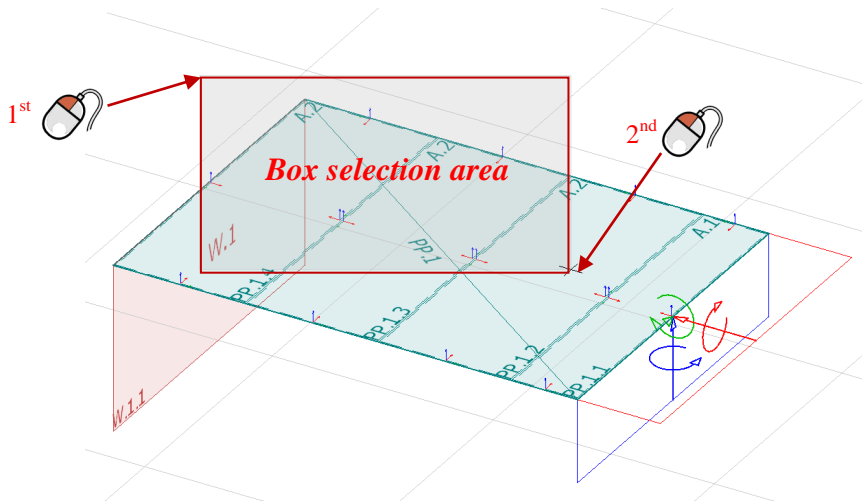

-  on an object pops up the available commands depends on where the user clicks.

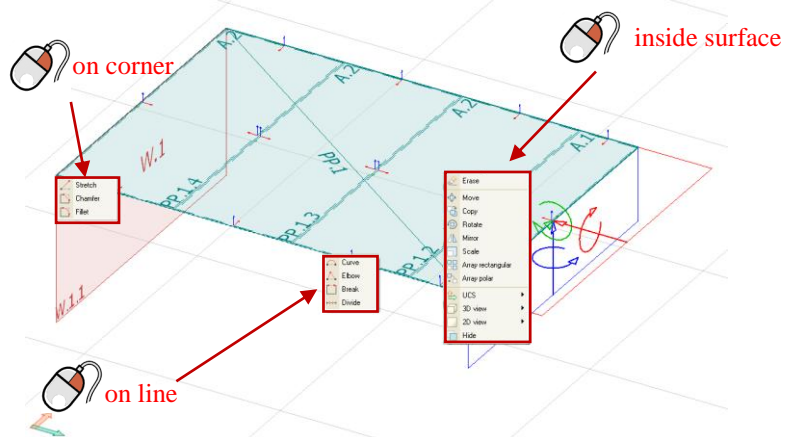

-  none of the objects hit pops up 'Modify' commands.

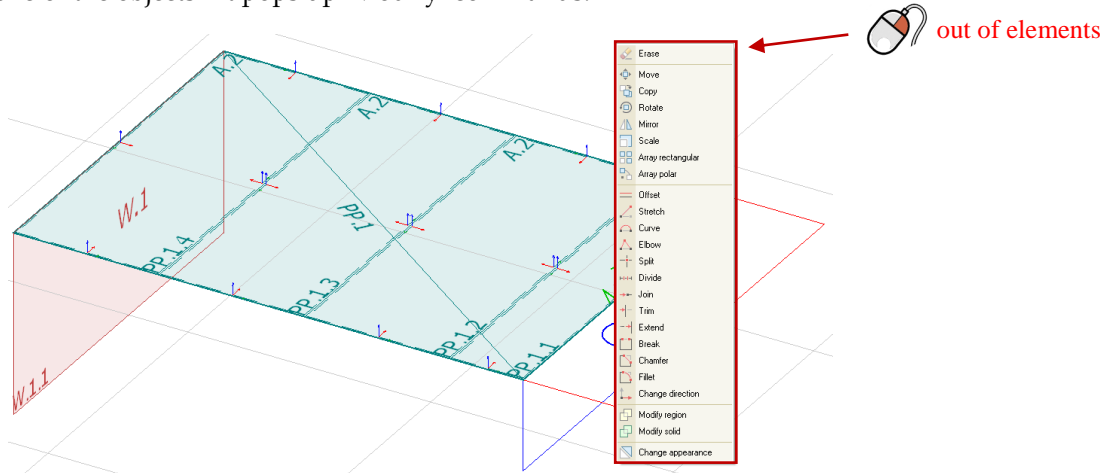

2.3 Guide lines and Tracker

A new editing tool, **Guide lines and Tracker** is developed in FEM-Design 10.0. They appear when any commands started and assist the user in modeling and modifying elements in a much more effective way. Guide lines are displayed temporarily during modification or drawing to assist user to find desired point in a fast and easy way. There are two kinds of Guide lines **Straight** and **Circular**. The Color and Angle step can be set in the *Settings/Environment/Guide line and Tracker*. All features of Guide lines can be turned OFF/ON in its Setting dialog. There are three colors of Guide lines in FEM-Design 10.0. Dark green line will be drawn if the Guide line is parallel with the X axis of UCS, orange line will be drawn if it is parallel with the Y axis of UCS and light green (as default color) line will be drawn for any other guide line.

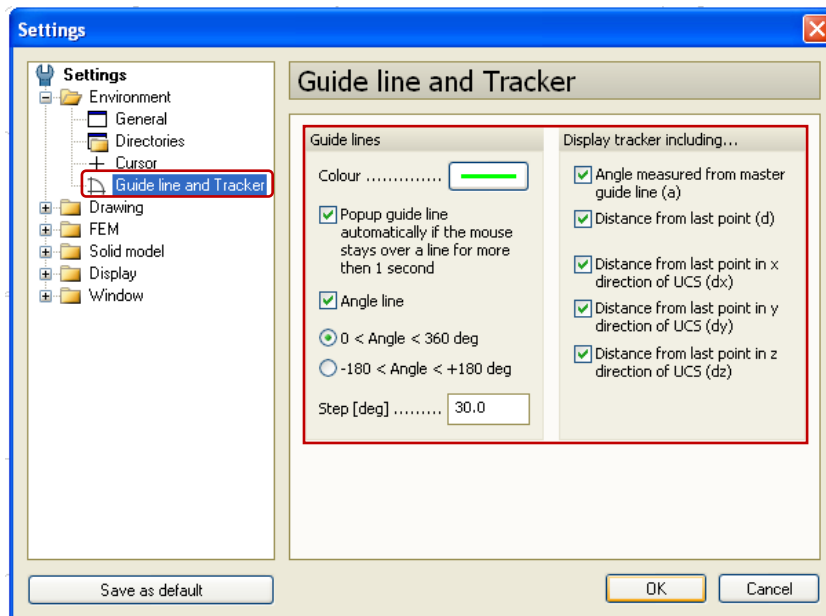

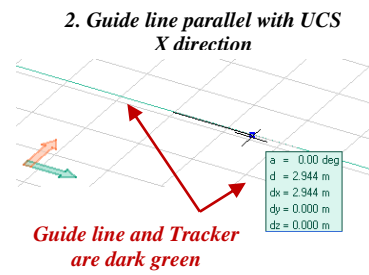
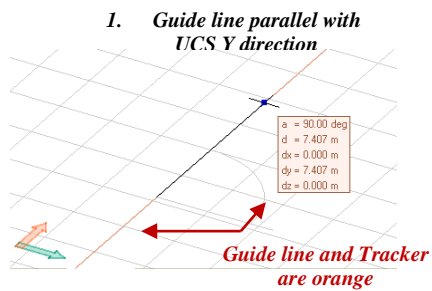

	Stand	Click RB
Along line or arc	Parallel guide line	Parallel guide line
Line's middle or end point	Perpendicular guide line	Perpendicular guide line
Guide line	-	Remove that guide line

Guide lines can be defined on the following ways:

- It appears automatically after 1 second, if mouse stands over a line



This function can be turned off in its Settings by unchecking „Pop up guide line automatically if the mouse stays over a line for more than 1 second“





- on a line (straight, arc, circle or any object having these kind of geometry)

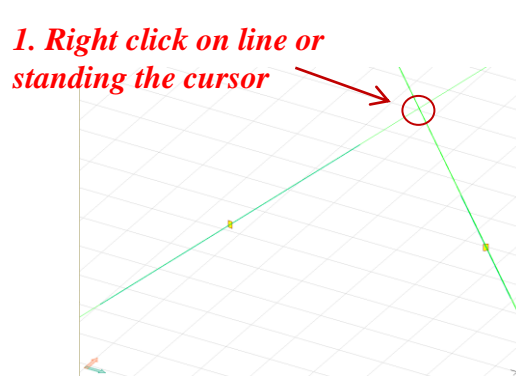
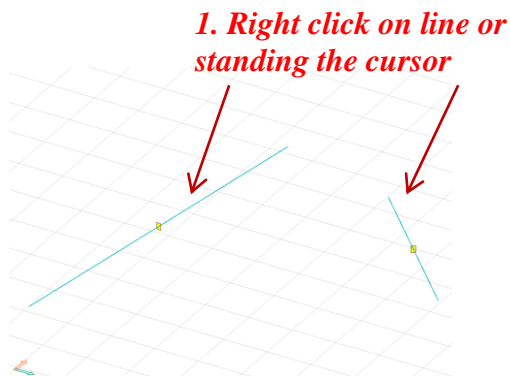

Virtual intersections can be found easily with Guide lines



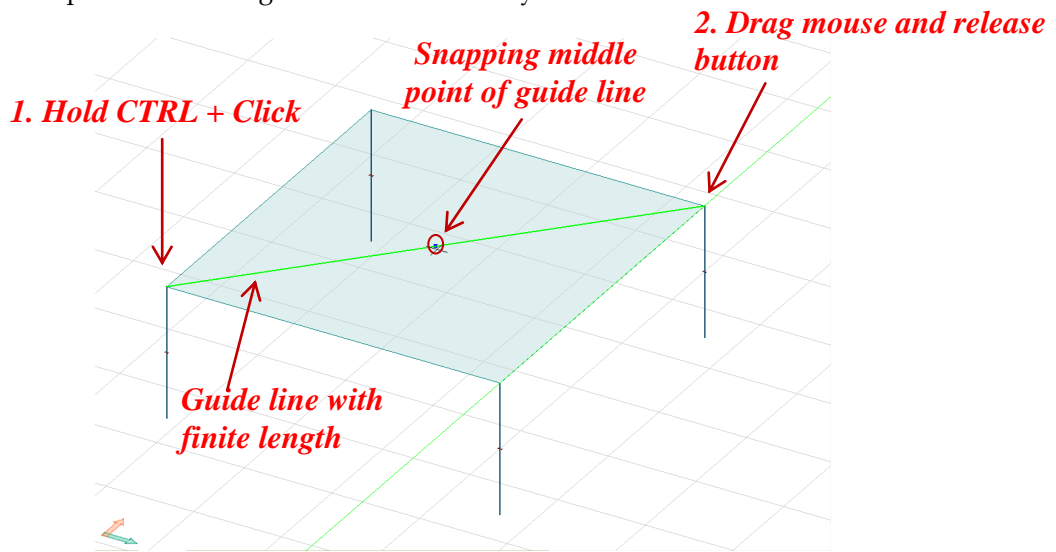

-  and drag mouse to define arbitrary guide line. If  is pressed, the line is created with finite length (from start point to end point), otherwise it will have infinite length.
-  Middle point of a rectangle can be found easily with Guide lines



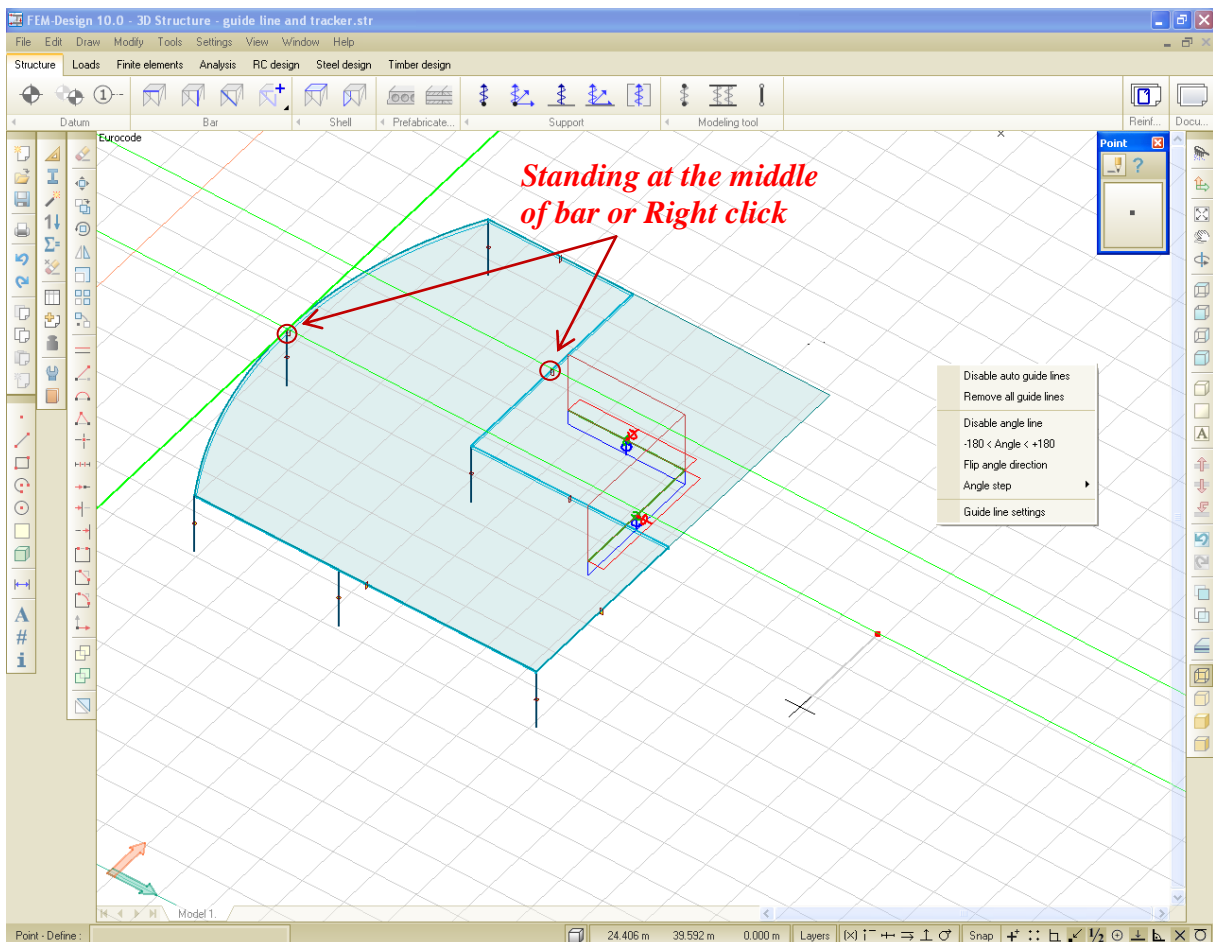

Guide lines are drawn in 3D, but Master Line (thick line) from which angle is measured, can only be placed in UCS or in a plane parallel to UCS.

- **Perpendicular** guide line appears if mouse cursor stands over the end or middle point of a line, otherwise **Parallel** guide line appears.

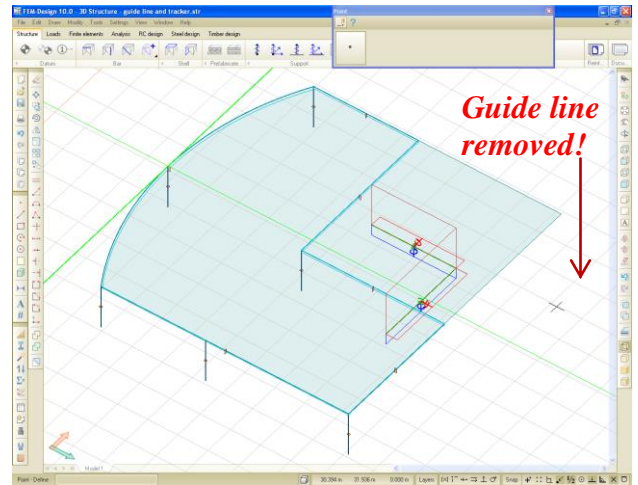
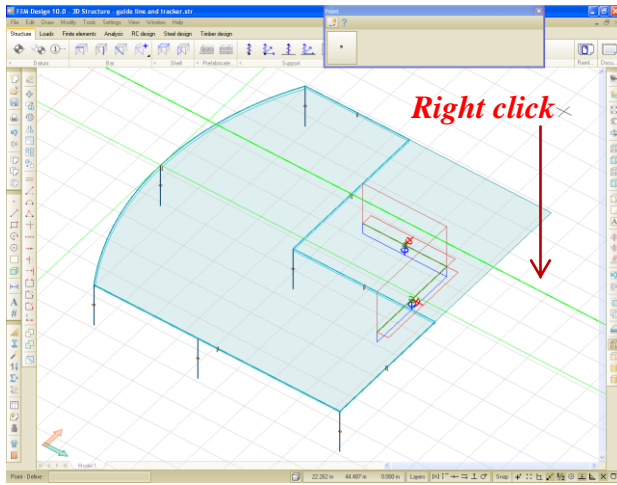

-  over guide line will remove that guide line.



- By  over snap-free places, guide line settings will pop up.
- Snapping on a Guide line +  will stick the pointer to that guide line.

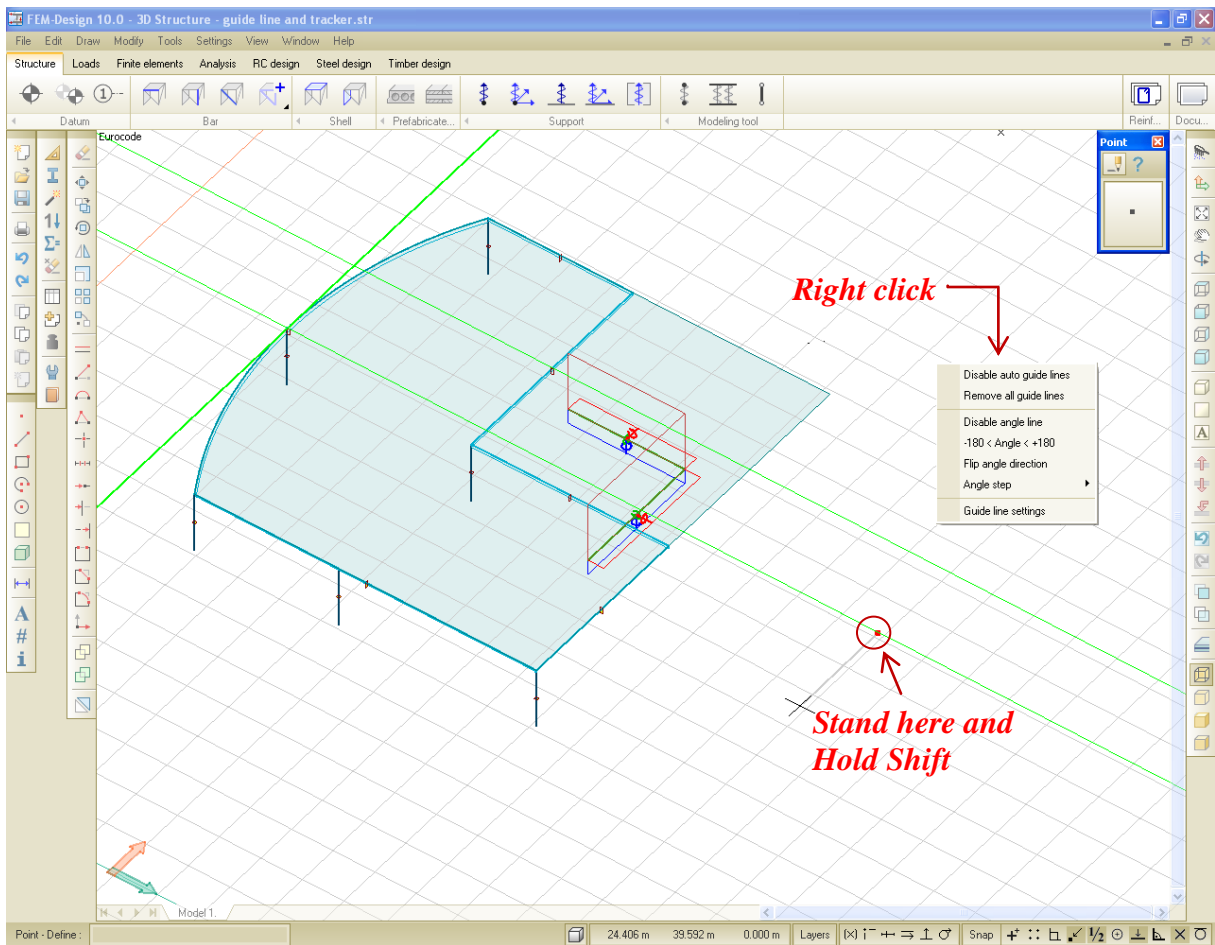

A new innovation in FEM-Design 10.0 is the **Tracker tooltip** which shows **Angle**, **Distance**, **dx**, **dy** and **dz** from the last point. It pop up next to the cursor while drawing and the tracker will be the same color as the Guide line.

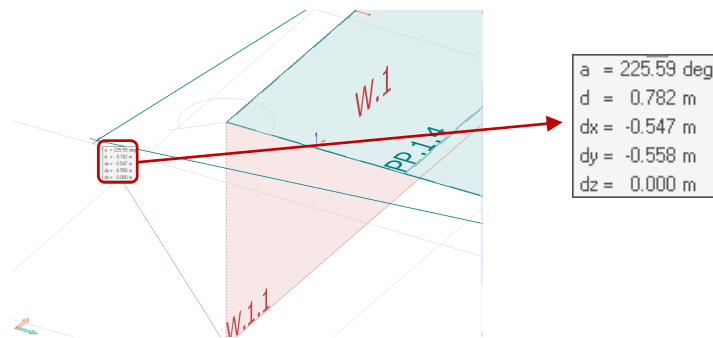

2.4 UCS

UCS command became smarter and provides more possibilities.

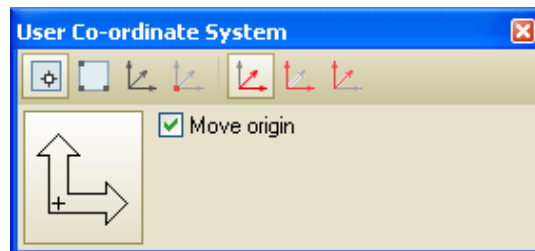

- 'Object plane': UCS X and Y axis will be parallel with the object's local coordinate system's X'Y', X'Z' or Y'Z' plane, depending on which option have been chosen.

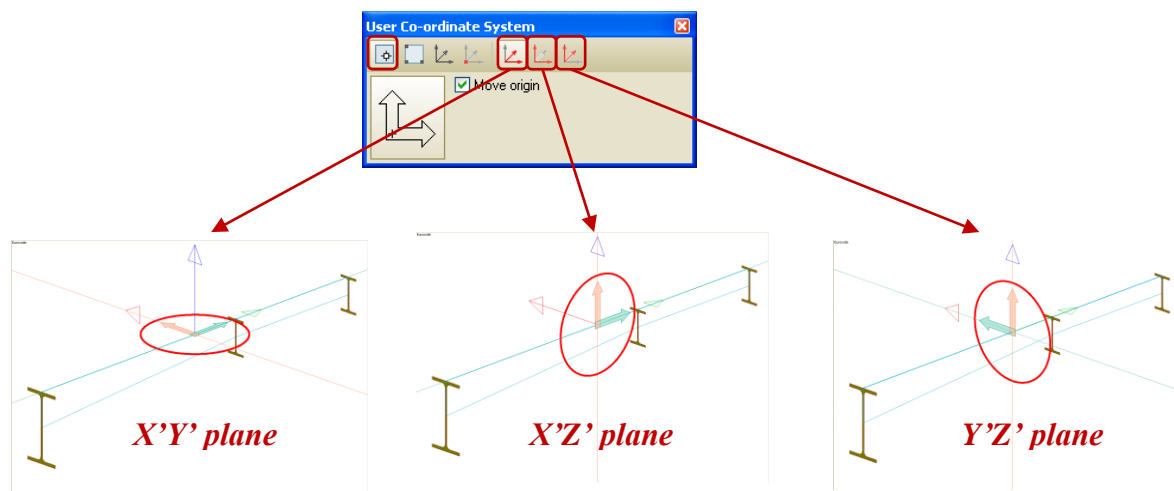

Note: If 'Move origin' is checked, the UCS's origin will be moved to the object's local coordinate system's origin.

- '3 points': The UCS can be defined by 3 points. The 1st and 2nd point will declare the UCS X axis and the 1st and 3rd point the UCS Y axis.

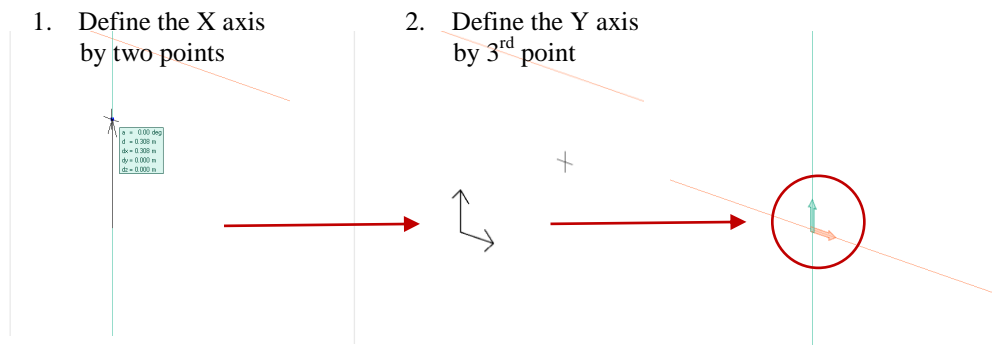

- 'Global system plane': With this command it's possible to set the UCS axes parallel with the global coordinate systems' axes with similar options to 'Object plane'.

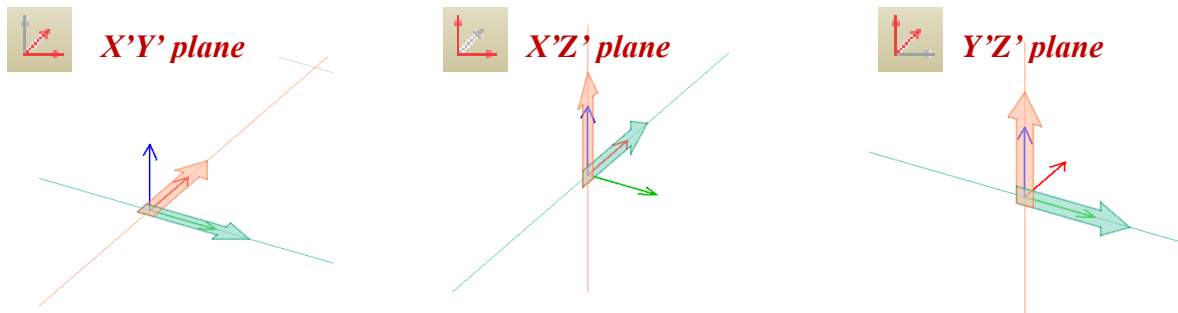

3 STRUCTURAL DATA

3.1 Datum

3.1.1 Axis

It's possible to declare axes by selecting lines.

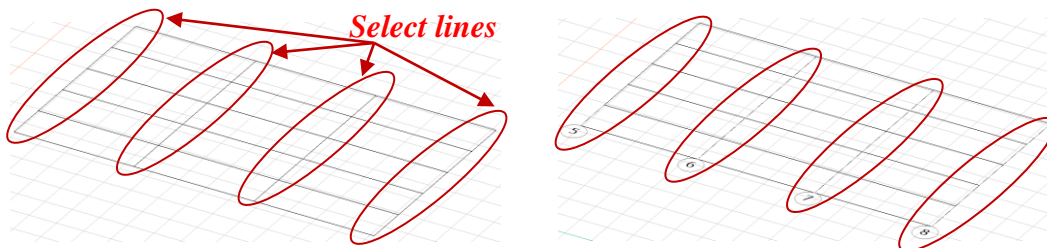
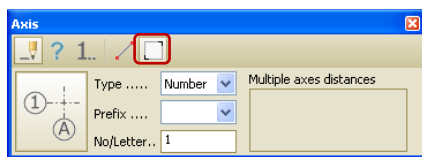

3.1.2 Storey

Storeys are handled similarly to Storeys of Predesign 9.0. Horizontal sizes of storeys has to be set, the first size parallel with global X, the second size is parallel with global Y axis. Foundation level defines the position of the lowest storey. Storeys can be added one by one by 'Insert' button. Default height of a storey is 3.0 m. If row of an existing storey is active in the table when pressing 'Insert', the height of

the new storey will be the same as the current storey. A set of storeys can be defined by 'Generate' command, in a similar way as in FEM-Design 9.0.

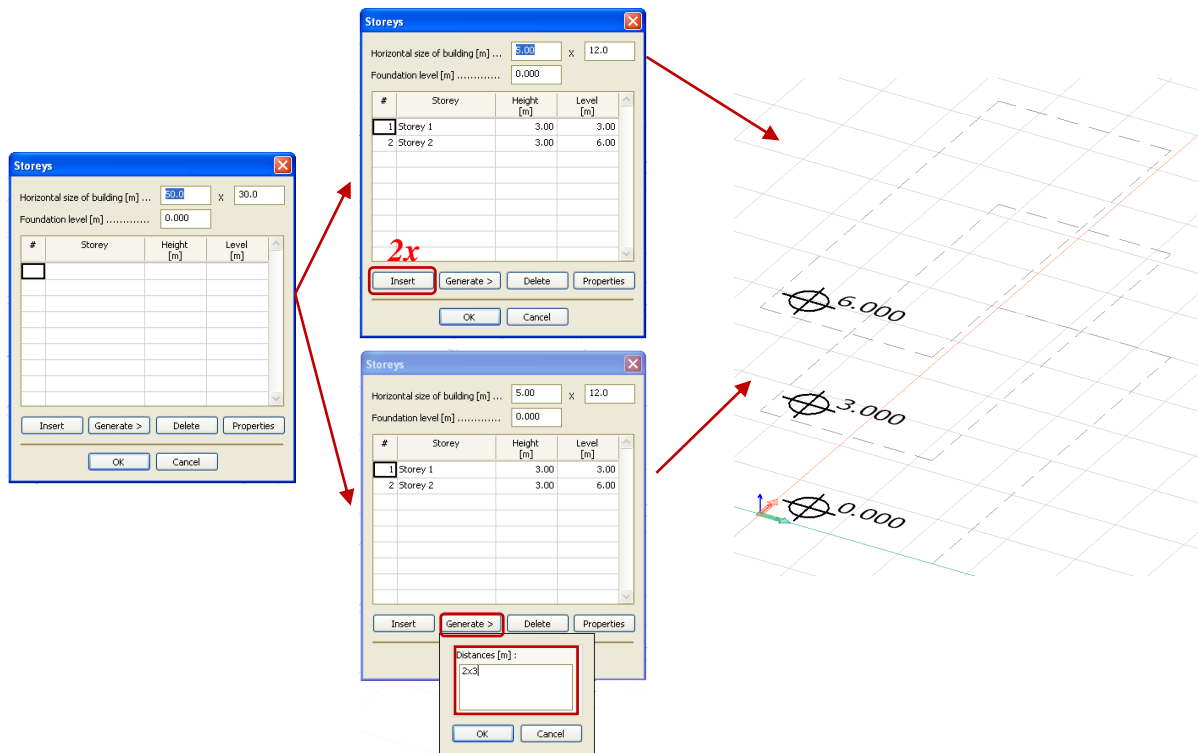

Content of table can be manually modified. Modifying the height of any storey will resize walls and columns of the current storey and move the other objects to belonging storey. Storeys are rotatable and movable together. If storey is deleted from the 'Storey' dialog with 'Delete' command all the belonging objects will be deleted, too. A storey can also be erased with 'Erase' command, in this case belonging objects will not be deleted.

'Copy storey' function of Predesign 9.0 is now implemented in all 3D modules. It makes possible to copy structural objects and loads from 'Source' storey to storeys selected from the 'Copy to' list, and if 'Copy load' is checked all loads will be copied, too.

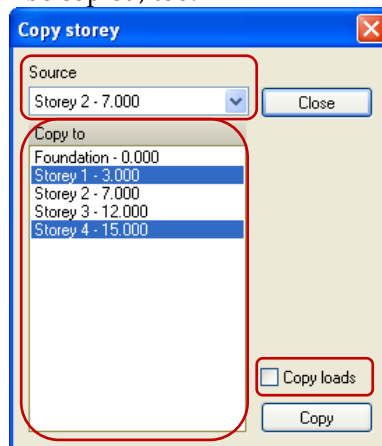

3.2 Bars

Structural dialogues are redesigned and the whole concept of bars has changed. As all **structural** elements in FD 10.0, bars have two representations: **analytical** elements and **physical** elements.

Analytical elements are used for calculation. Analytical element(s) of a beam or column can be either bar or shell model(s). Physical element is a solid that describes the physical extent of the object. It

makes possible to store information that are important from architectural point of view, for quantity estimation, or for formwork plans.

A structural bar object may have more than one analytical element and/or physical element. For example a bar with closely built up cross-section has one analytical element and more physical ones. See more example in Chapter 3.2.4 and 3.2.5.

3.2.1 Columns

Two new options are implemented in Column command. Column placement can be defined **above** or **below** the defining point.

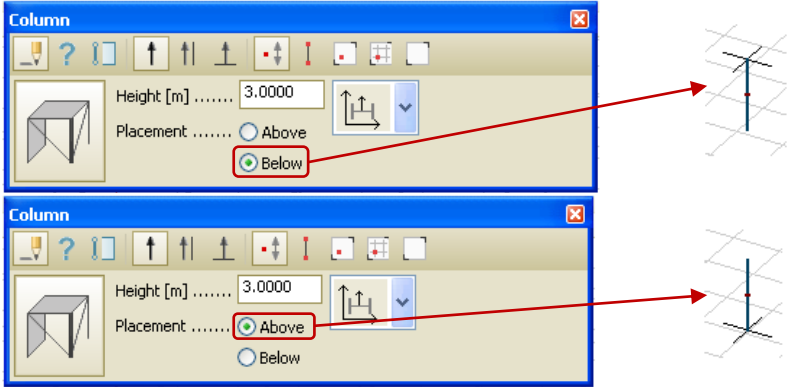

Columns can be defined by 'Select axes' option, too.

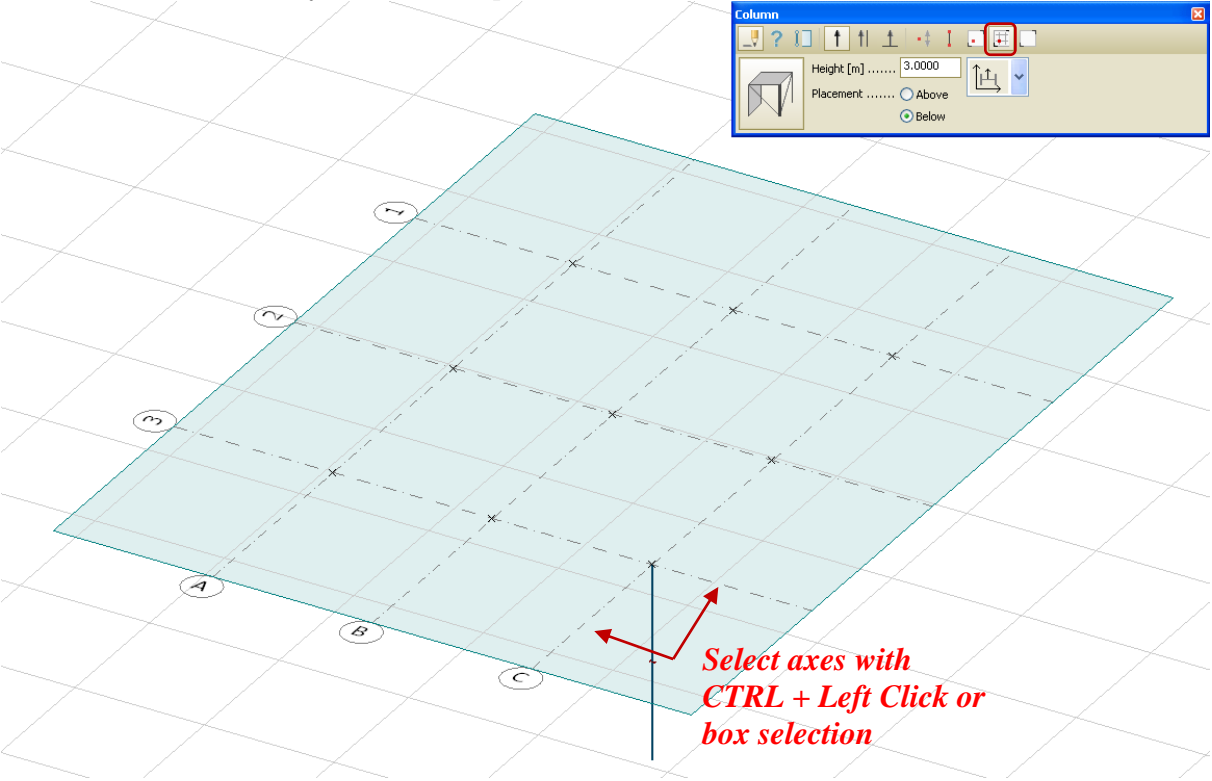

Columns can be defined by 'Select point' option, too.

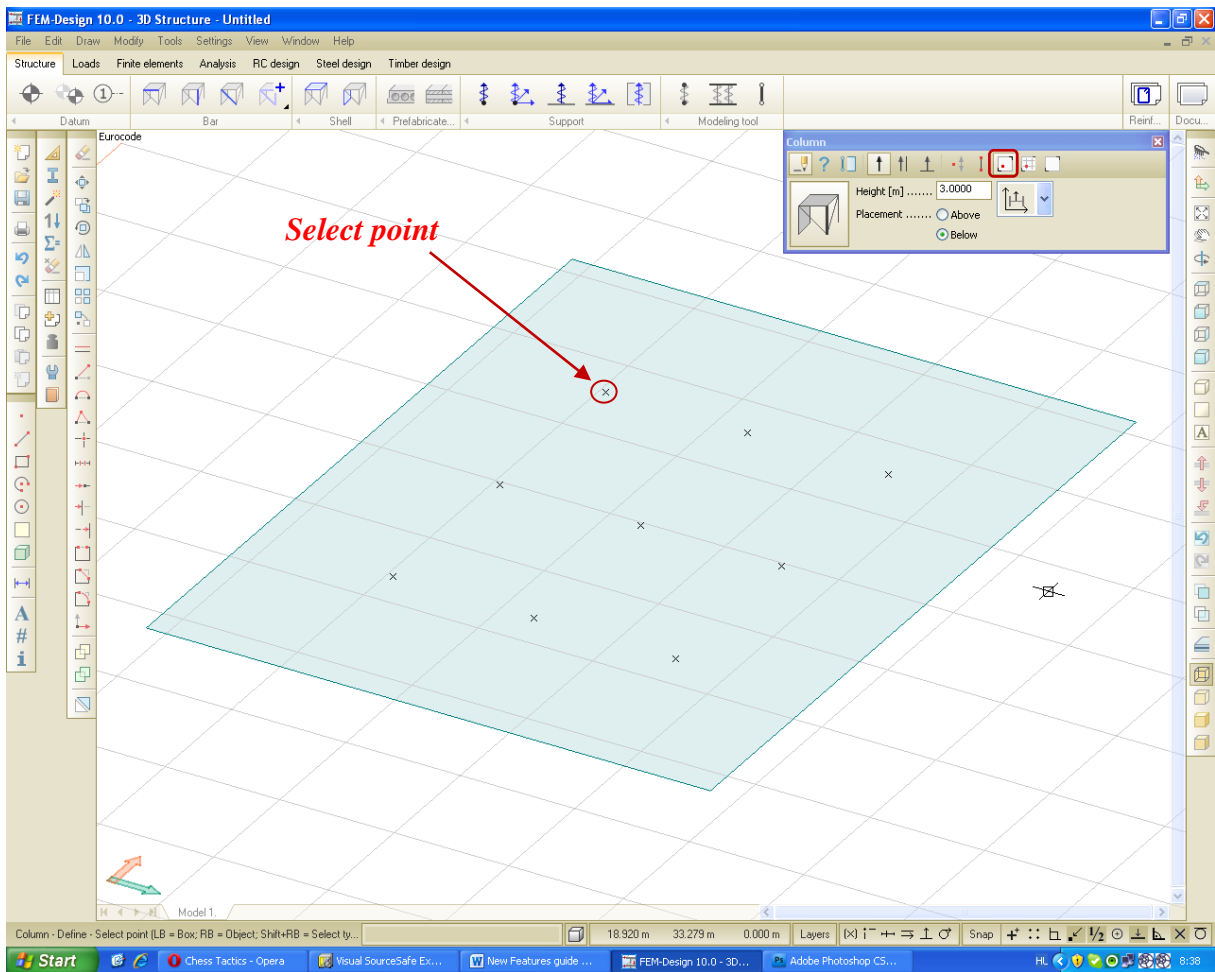

3.2.2 Cross-sections

Cross-section handling in version 10.0 has a new concept, the Section tab of properties dialog has changed. Cross-section library can be edited by adding, deleting, modifying a new 'group', 'type' and 'size' of cross sections. Import and export of section library are also possible.

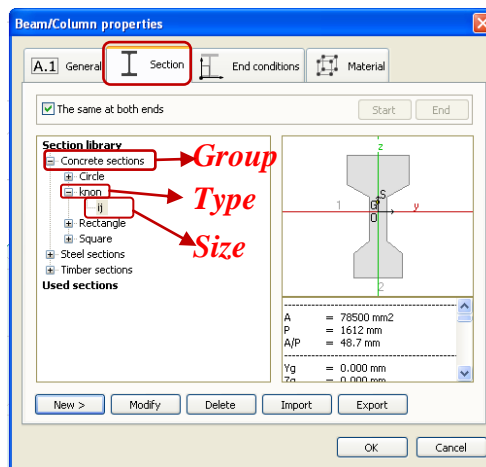

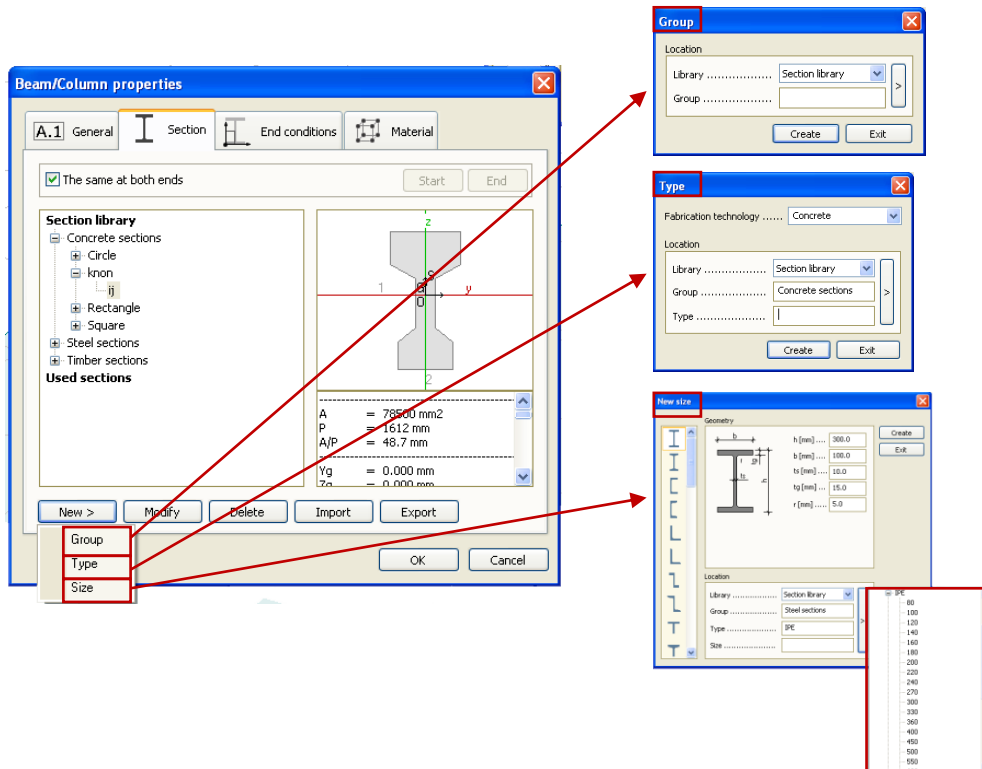

When user defines a new group/type/size, it can be added to Section library of FEM-Design or into the 'Used Section' library.

Cross sections in 'Used Section' library are available in that file only.

Parametric cross sections can be defined by 'New >' / 'Size' button. The dialogue structure is similar to version 9.0. By clicking on the '>' sign will pop up a dialog where the user can navigate in the section library easily and fast. Multiple cross-sections can be defined by 'Create' button without exiting the dialog.

By 'Modify' command name and library of 'groups', 'types' or 'sizes' can be modified. In case of 'types' prefabrication technology also can be set.

Importing and exporting cross section library is possible in version 10.0.



Cross-sections defined by different users can be shared by this function.

3.2.3 Varying cross-section

Different cross-sections can be defined for start and end section of bars, with the following restriction:

- fabrication technology and shape type of the two sections must be the same.
- geometrically they have to fit which means that their contour line pairs have to be parallel with each other.

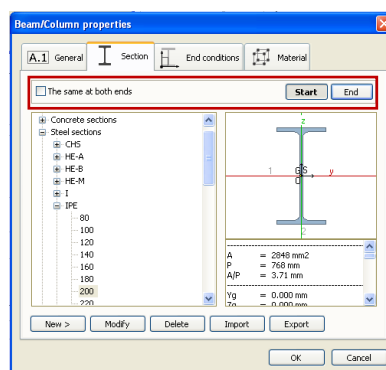

3.2.4 End conditions

'Connection' and 'Eccentricity' tab of FEM-Design 9.0 are merged into 'End condition' in version 10.0. Eccentricity of the cross section, DOF of the end sections and the eccentricity type can be defined here.

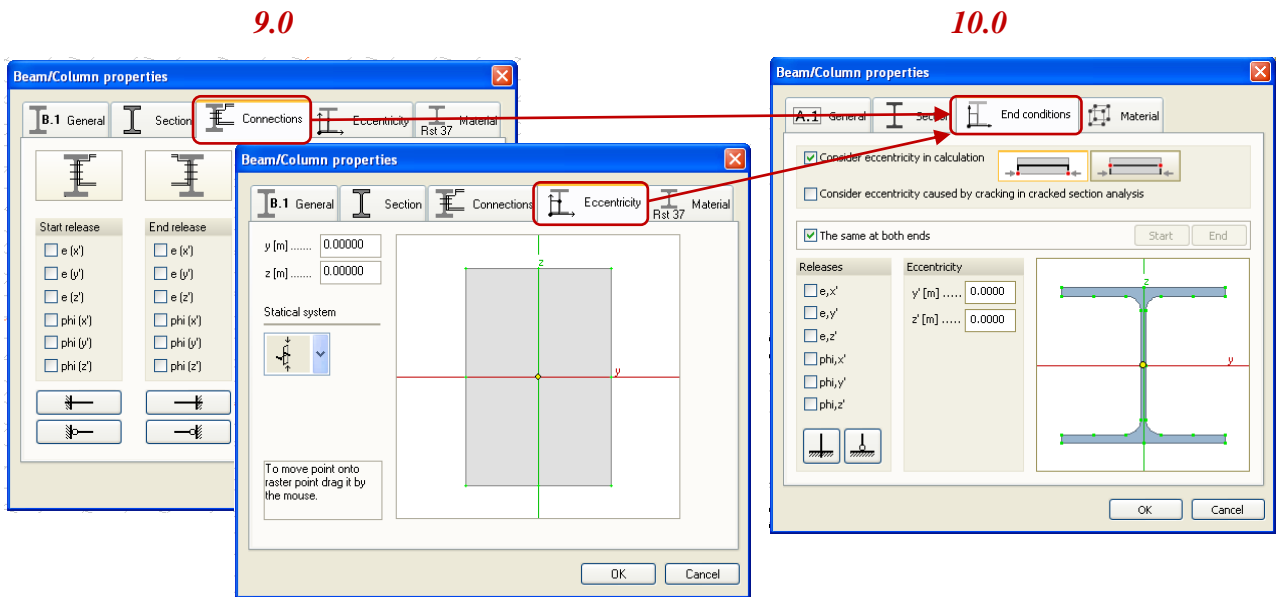

3.2.5 New eccentricity options

Two types of eccentricity model can be set for bars. First type ("End releases applied at the ends of the theoretical axis") is typically used for modeling RC bars which work together with concrete slabs (slab normal forces transfers to the bar) and second type ("End releases applied at the ends of the gravity (physical axis)") is for modeling single plate and bars which are not working together. It's possible to set different individual eccentricities in the start and in the end cross section. Managing the preview window has changed. Characteristic eccentricity points can be selected by clicking, rather than dragging the yellow eccentricity point.

3.2.6 Analytical model

Analytical model was a separate command, but in version 10.0 it is built in the Beam and Column tool window.

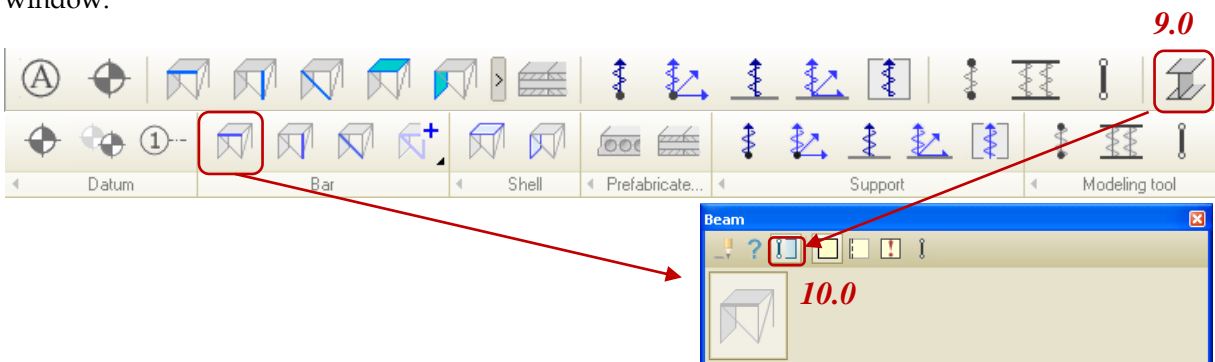

Choosing a bar with 'Shell model' command will convert the bar into shells.

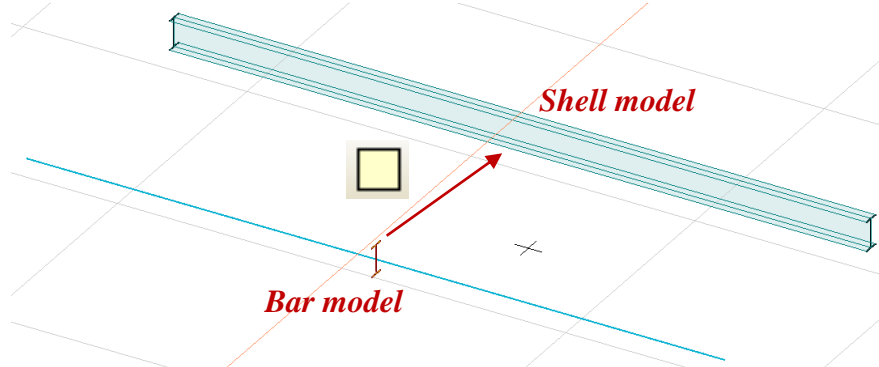

Shells edge connection can be defined by 'Edge connection' option.

'Reset shell model' resets all previous modifications.

The shell model can be restored into bar model with 'Bar model' command.

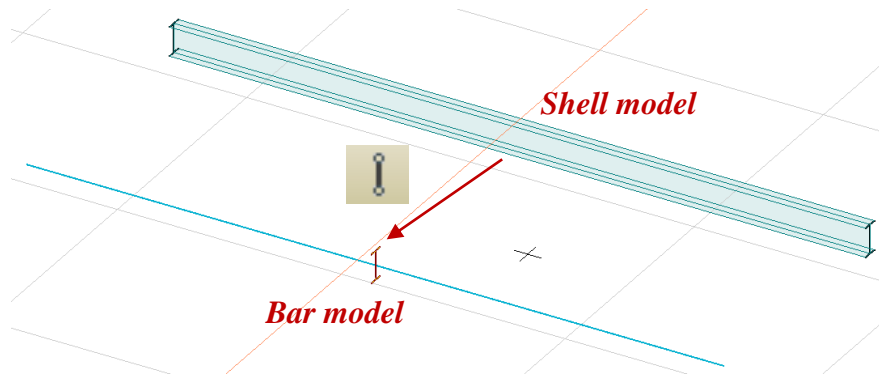

3.2.7 Apex

Apex is a specific connection tool which connects bars which corresponds to the following conditions:

- Their cross-sections must be rectangular
- Their Y axes are parallel and point into the same direction

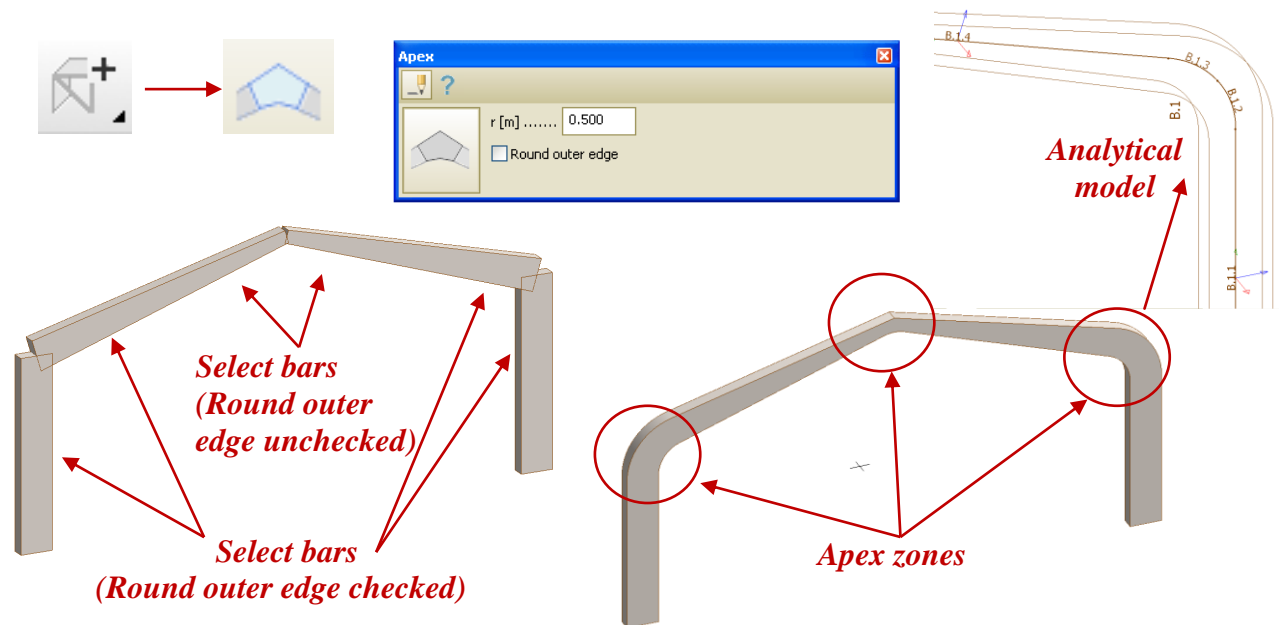

If 'Round outer edge' is checked the outer edge will be rounded too.

Apex zones with their connected bars are only one physical element but it has more analytical element.

In version 10 Design checks according to EC-5 are available for apex zones for Timber bars.

3.2.8 Intermediate section

With 'Intermediate section' it is possible to modify varying cross section anywhere along the bar. Bar cross-section varies linearly between two neighboring sections, or between end and neighboring intermediate sections. The cross-section and the insertion point (eccentricity) can be defined in their tab.

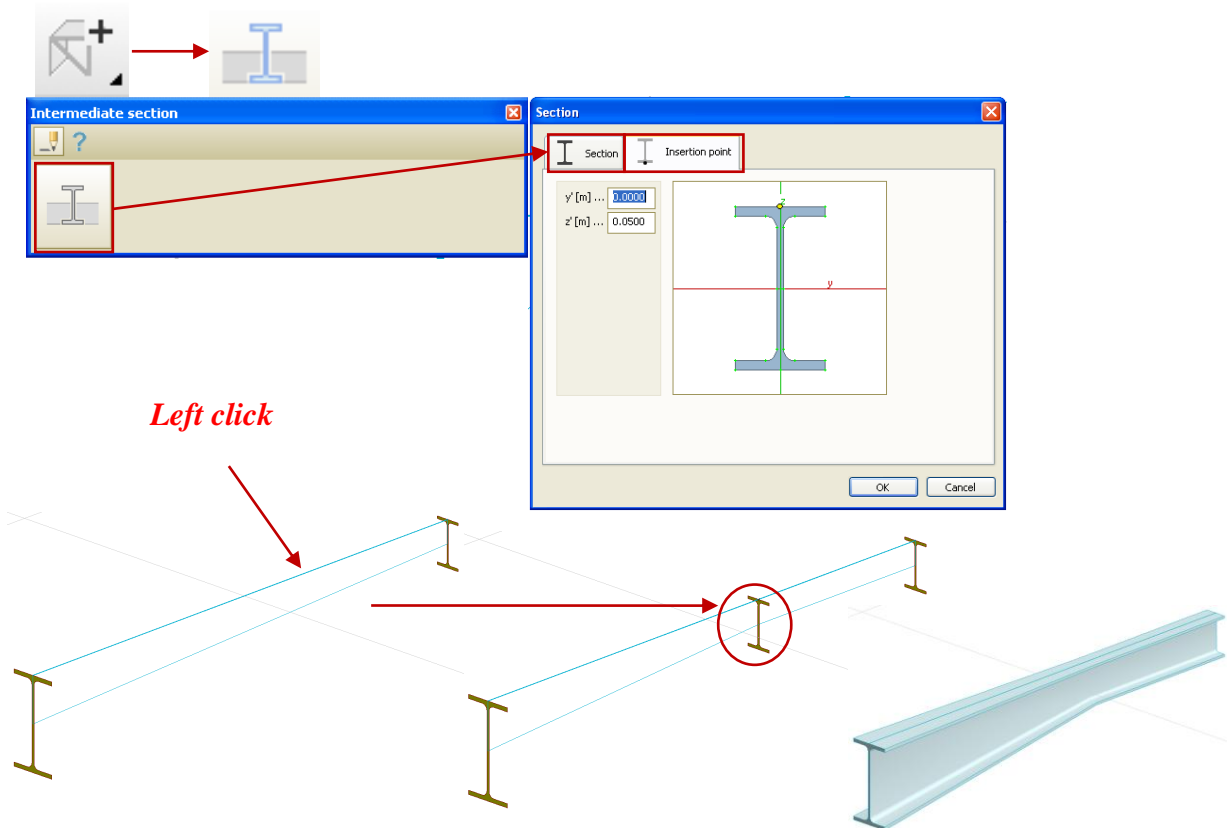

 Intermediate section can be used in bar with the same section shape and same Prefabrication technology.

3.2.9 Settings for bars

In the Bar settings the visualizing Scale of the Section is removed in version 10.0.

3.3 Shells

As all **structural** elements in FD 10.0, shells have two representations: **analytical** elements and **physical** elements.

Analytical elements are used for calculation. Analytical element of a plate or wall is called shell model. Physical element is a solid that describes the physical extent of the object. It makes possible to store information that are important from architectural point of view for quantity estimation or for formwork plans.

3.3.1 Walls

Similar to the Column, two options are implemented in Wall for placement of the wall **Above** or **Below** the defining line.

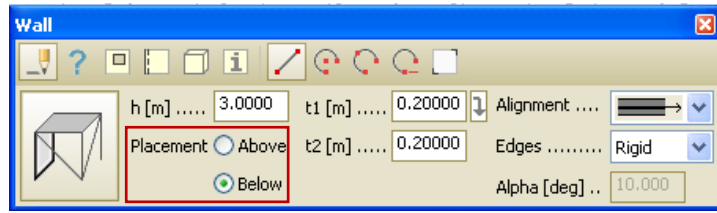

3.3.2 Eccentricity

Now in Plate and Wall objects eccentricity can be considered in calculation and it is not only to display. Additional to this there is also another option to 'Consider eccentricity caused by cracking in cracked section analysis'.

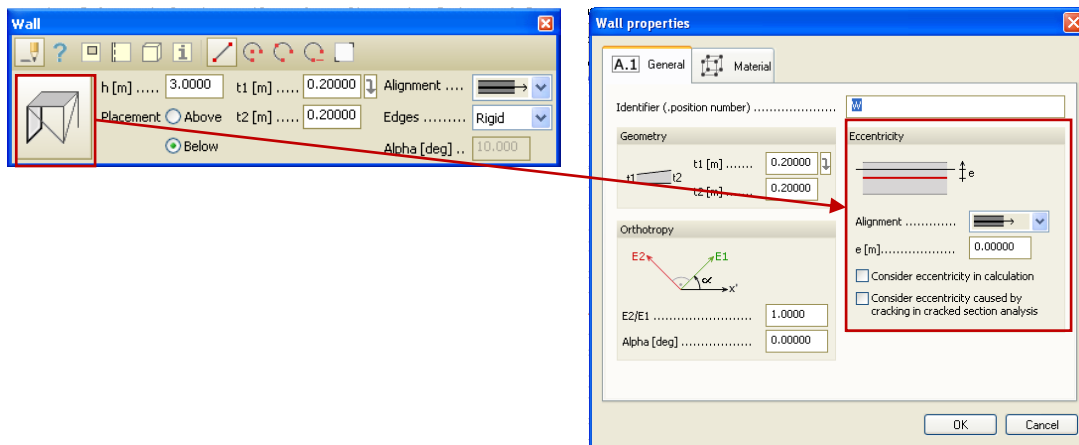

Considering the effects of cracking causes an eccentricity because the uncracked and cracked section's lines of gravity aren't at the same height.

Uncracked analysis

Cracked analysis

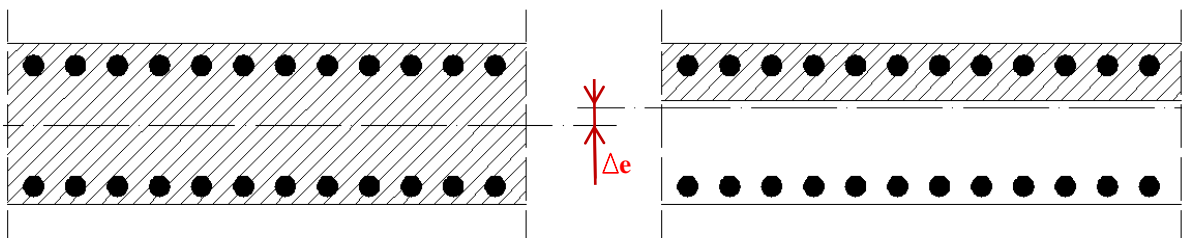

3.3.3 Physical extent

It is possible to change the physical model of the structural elements without influencing analysis, but it makes difference in 'Quantity estimation'. The command helps to communicate effectively with architectural programs and very useful when creating formwork plan.

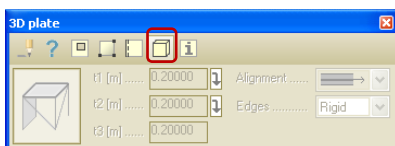

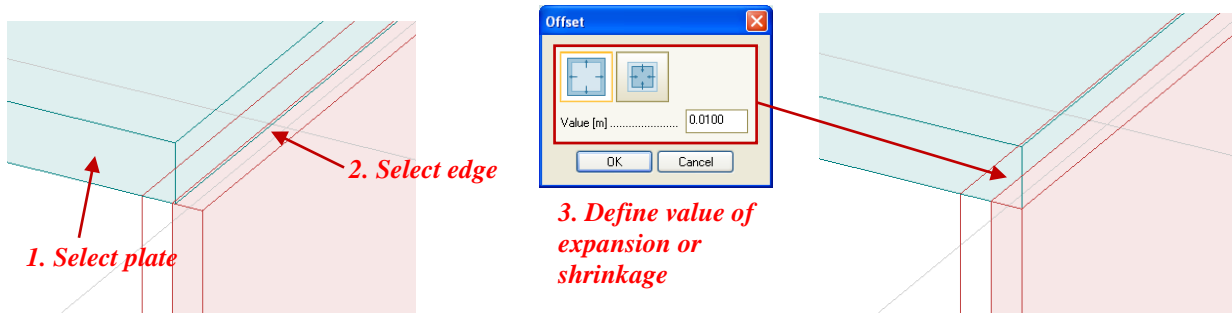

3.4 Prefabricated elements

A new innovation for all prefabricated elements is that panels defined as a group will be handled together.

3.4.1 Profiled panels

Using Profiled panel command any type of prefabricated element can be defined, especially hollow-core panels.

Profiled panel section and material can be defined in the same way as at 'Bar' or 'Column'. In the General tab the panel group ID, the panel type ID, the gaps between panels, the orthotropy and the eccentricity can be set. In the 'Border' and 'Panel' tabs the DOF of the group and the single panels can be set.

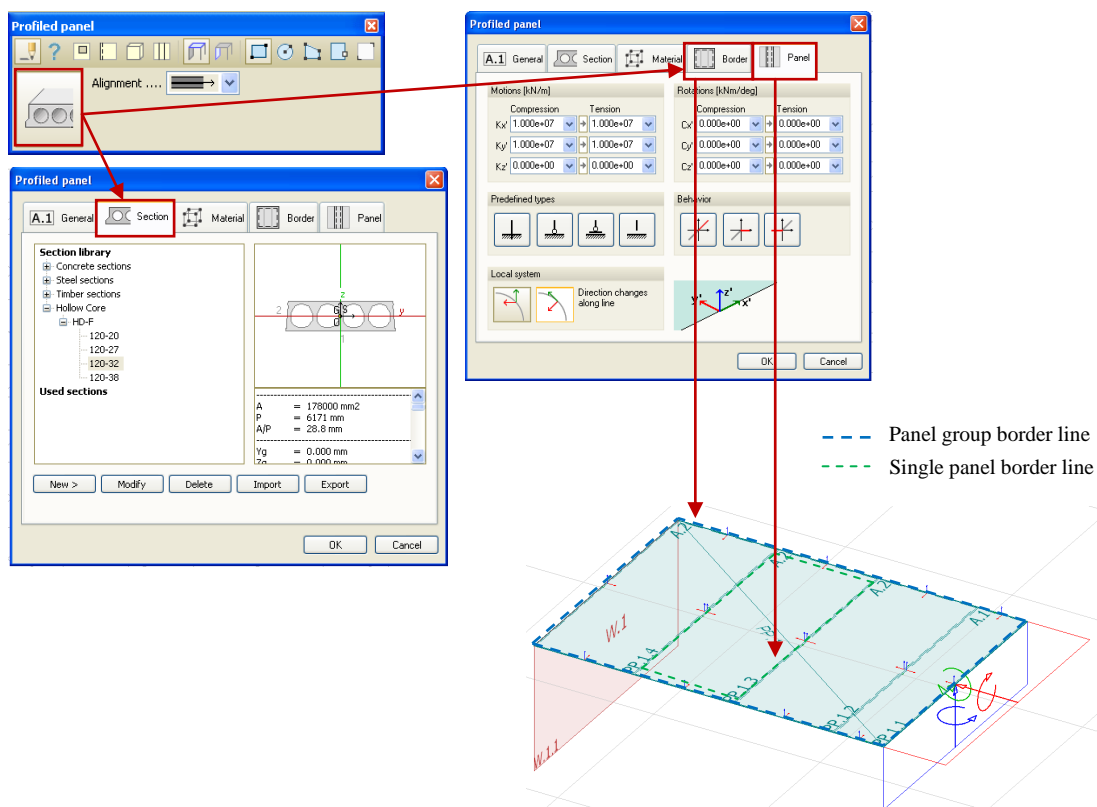

Note: Special DOF can be set for any single panel with 'Edge connection' command.

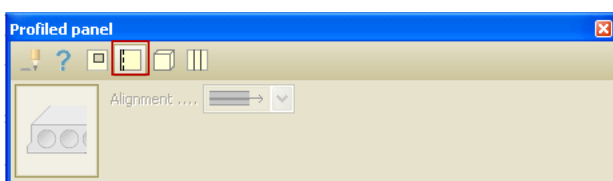

Profiled panel element group can be defined in the following steps:

- Define the main direction of panels (Base line is parallel with stiff direction)
- Define the geometry of panel group
- Place the anchor point



Guide lines help defining main direction easily.

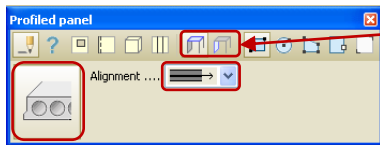

*Structure type
(Plate or Wall)*

1. Set type and properties

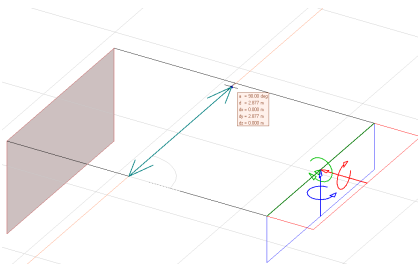

2. Define the main direction

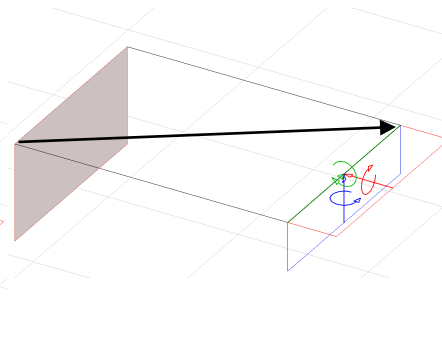

3. Define panel geometry

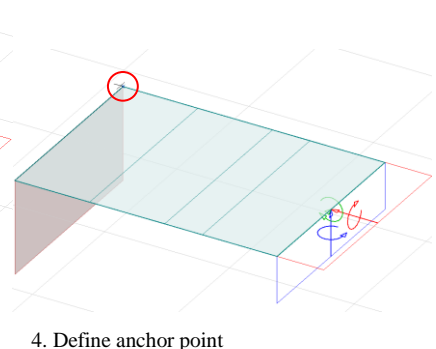

4. Define anchor point

In profiled panel's properties, the connections of the edges of the panels can be set for 'Border' and 'Edges'. There are three additional commands built in 'Profiled panels', **Base line**, **Swap panels** and **Cut panel**.

'Base line' command allows changing manually the Base lines' anchor point.

'Swap panels' will swap two selected panels which one is a truncated panel.

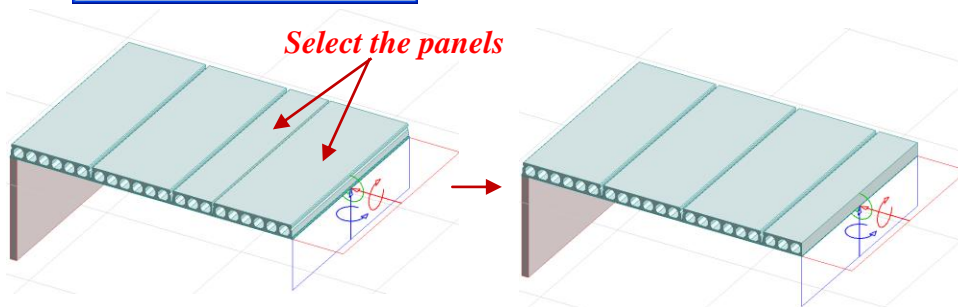
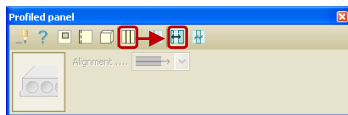

'Cut panel' will change the placement of the truncated panel.

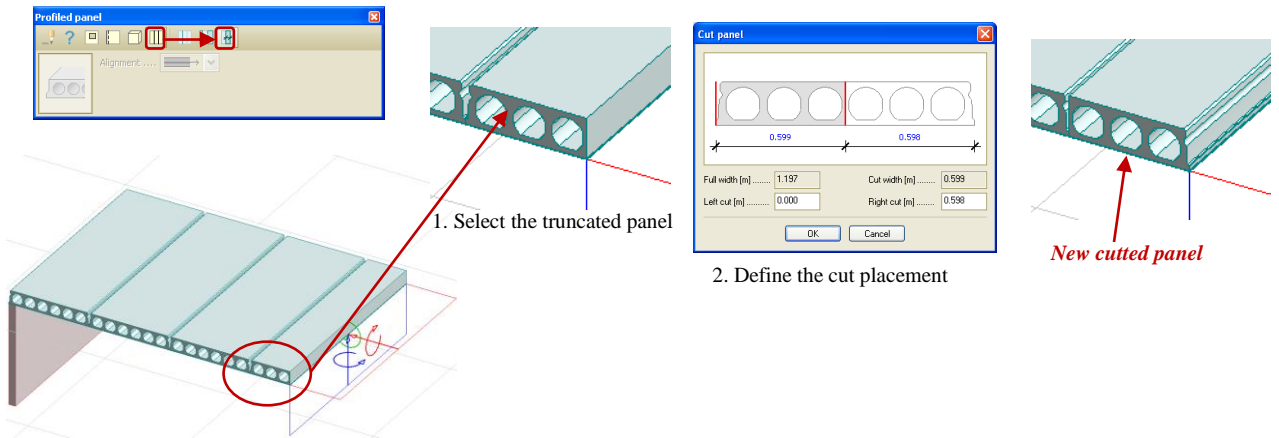

Panel groups, group member panels and panel shapes have their own IDs.

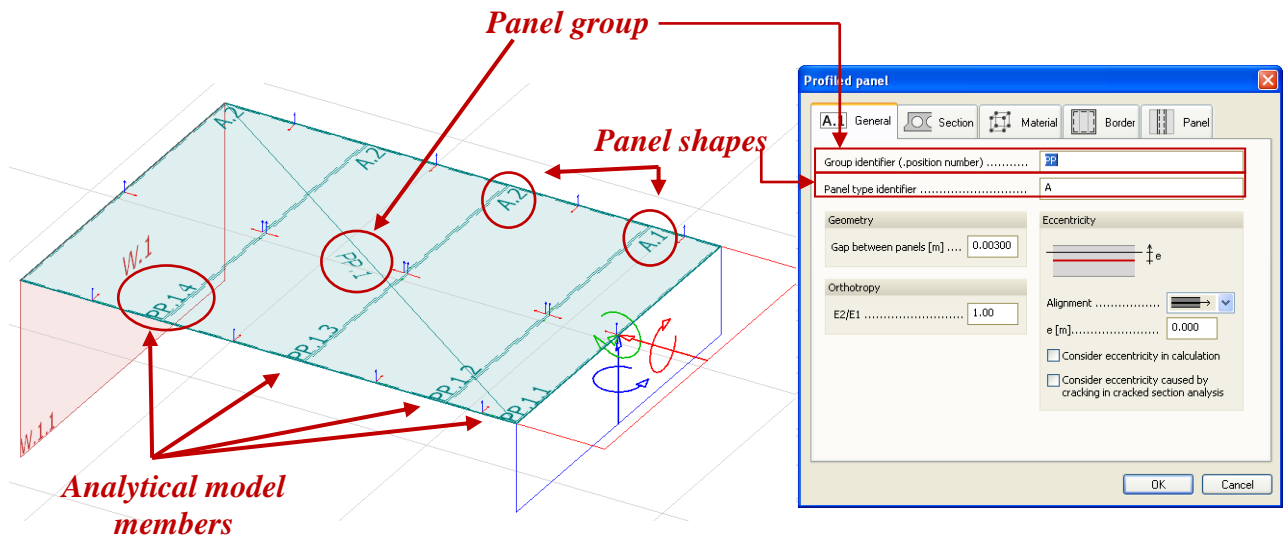

Profiled panel has separate tab in Quantity estimation dialog.

Storey	Struct.	Identifier	Quality	Section	Type	Length [m]	Width [m]	Height [m]	Area [m ²]	Weight [t]	Sum
	Plate	PP-1	C30/37	HD-F 120-2/ A.2		3.000	1.197	0.200	3.591	0.864	3
	Plate	PP-1	C30/37	HD-F 120-2/ A.1		3.000	0.599	0.200	1.796	0.432	1
	TOTAL									3.023	4

3.4.2 Timber panels

Timber panels are handled in a similar way as profiled panels.

3.5 Supports

In version 10.0 supports have their own ID and it can be set in their Properties dialog. ID is great help while using the table output. It is very fast way to identify the objects in tables.

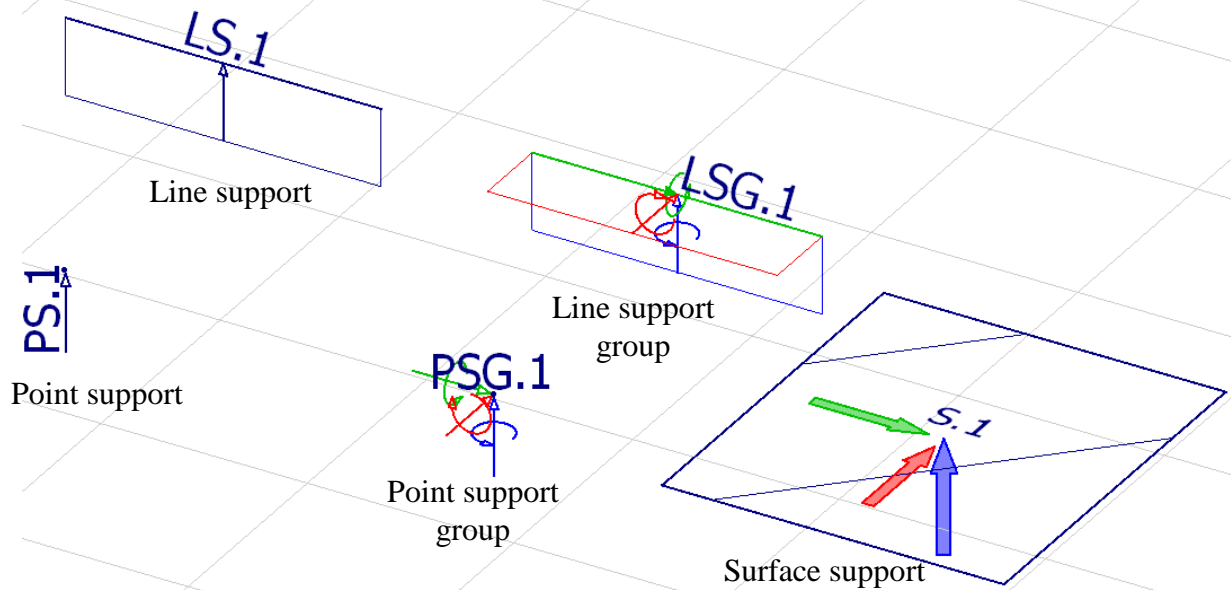

4 LOADS

4.1 Load generation direction

'Wind' and 'Deviation' load directions are defined by this object. Directions can be changed by 'Change direction' command.

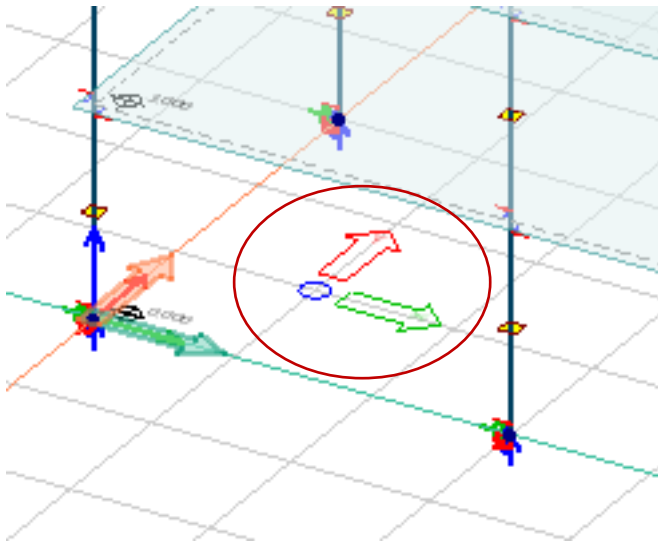

4.2 Load macros in 3D Structure module

Three load macros are implemented from Predesign to 3D Structure, 'Wind', 'Snow' and 'Deviation'. FEM-Design generates **wind load** according to Eurocode 1991-1-4 (wind load details are in Theory book). Line loads are generated on the edges of plates.

Wind speed, terrain type and direction of wind can be defined by the user, the values of wind loads are automatically calculated. Direction can be set by clicking the lower buttons. Directions refer to Load Generation Direction (see in 4.1).

Wind load



1. Set wind speed

2. Select terrain type

3. Select the wind directions

4.

Automatically generated load intensity for every storey

Direction definition field

Wind load dialog box showing input fields for wind speed (25.0), building height (12.0), and terrain type (II). A table lists storey levels and dimensions.

Storey	Level [m]	X [kN/m]	Y [kN/m]
Storey 1	3.00	3.30	3.30
Storey 2	6.00	3.30	3.30
Storey 3	9.00	3.30	3.30
Storey 4	12.0	1.65	1.65

Wind speed [m/s]: 25.0
 Building height [m]: 12.0
 Terrain type: II. Area with low vegetation such as grass and isolated obstacles (trees, buildings) with separations of at least 20 obstacle heights
 Direction definition field: [OK] [Cancel]

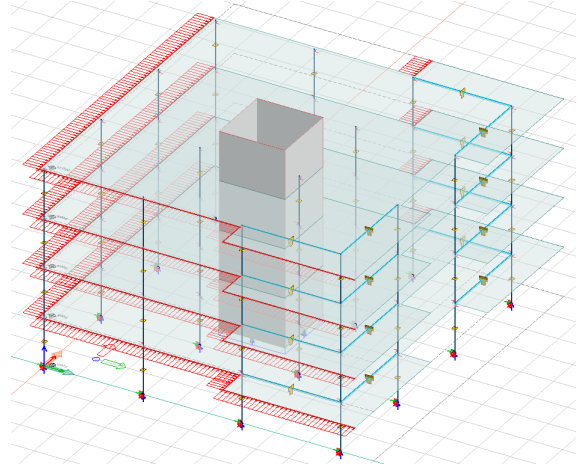

FEM-Design can generate **Snow load** according to Eurocode 1991-1-3 (snow load details are specified in Theory book). In the dialog the characteristic value of load can be defined and it is placed on the plates which are visible from the top. The snow load is a surface load and it is parallel with the global Z axis.

Snow load



1. Set value

2.

Snow load dialog box showing input fields for characteristic value (0.000) and applied value (0.000).

Characteristic value [kN/m²]: 0.000
 Applied value [kN/m²]: 0.000
 [OK] [Cancel]

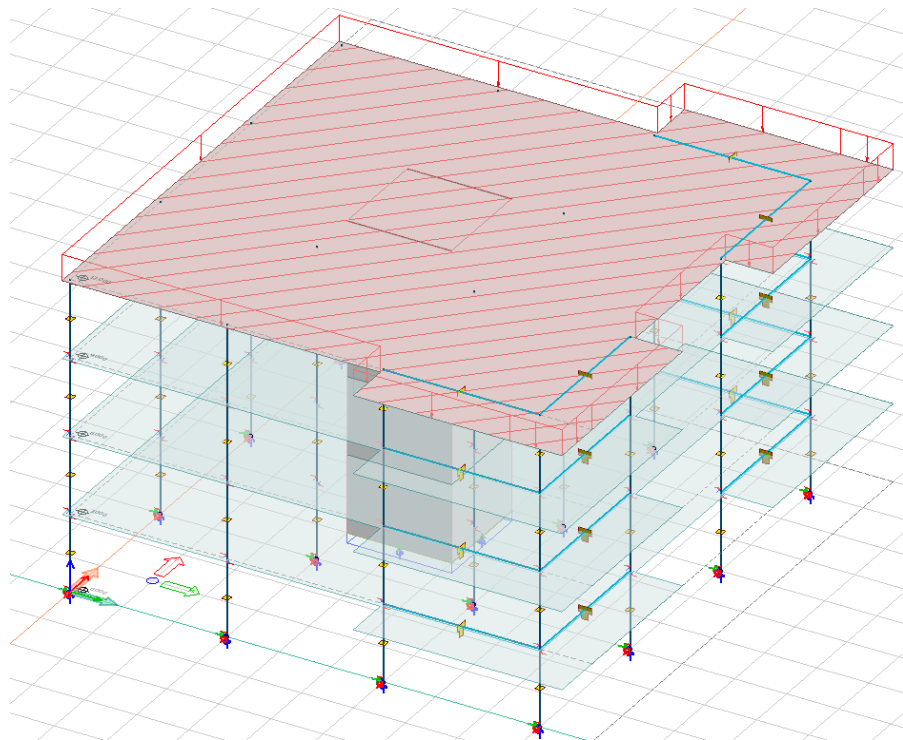

FEM-Design automatically generates 'Deviation' load according to EC.1 by considering dead load of the structure. Direction and α_h, α_m values can be set by storeys.

Deviation load



1. Select storey

Storey	Level [m]
Storey 1	3.00
Storey 2	6.00
Storey 3	9.00
Storey 4	12.0

Considered weight on storey [k] (Only self weight included!) 273

No. of supporting structures 19

Proposed value of alpha h 1.00

Applied value of alpha h 2/3 <= x <= 1.0 1.00

Proposed value of alpha m 0.725

Applied value of alpha m 0.725

Load value [kN] 9.70

Generate Close

2. Select direction

4.

3. Set α_h, α_m value

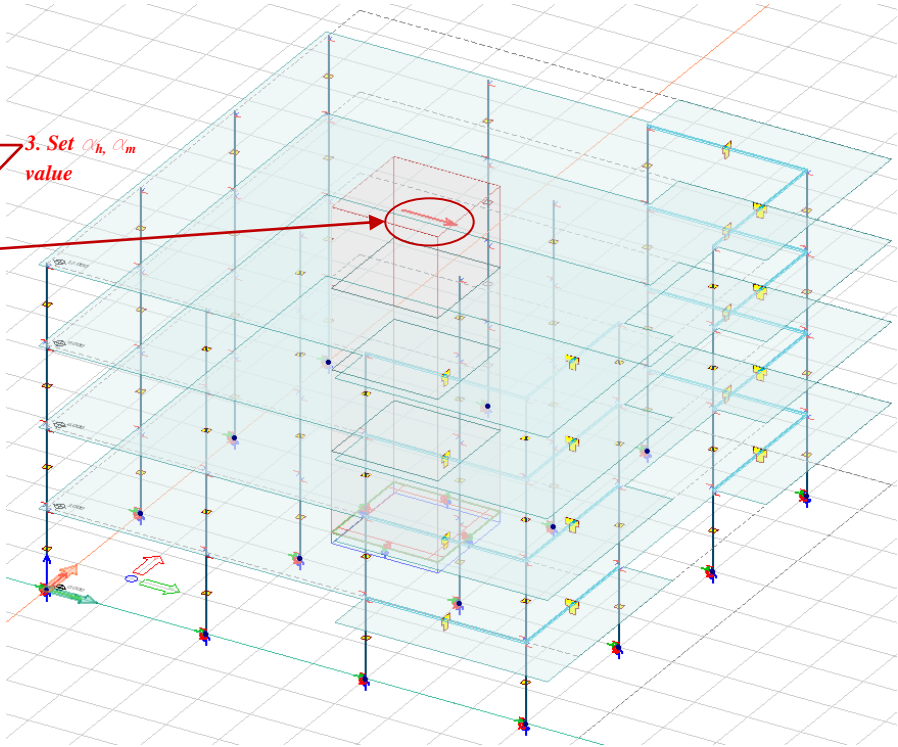

5 DESIGN

Selecting a bar in 'Utilization' table (available in 'Check', 'Auto Design' and 'Manual Design') shows the current bar on the screen. The selected bar element will be highlighted with black color.

The screenshot displays the FEM-Design 10.0 software interface. The main window shows a 3D model of a steel truss structure. A 'Check' dialog box is open, and the 'Utilization' table is visible in the bottom right corner. The table lists various groups and bars with their respective utilization percentages. A red circle highlights a specific bar in the table, and a red arrow points to the corresponding bar in the 3D model. The bar is highlighted in black in the model.

1. Steel bar icon in the toolbar.

2. 'Display table' checkbox in the 'Check' dialog box.

3. Red arrow pointing from the selected bar in the 'Utilization' table to the 3D model.

4. Red circle highlighting the selected bar in the 3D model.

Group	Applied profile	Max [%]	Min [%]
✓ Long	RHS 40x40x2.5	94	5
✓ BeC	RHS 20x20x2	75	14
✓ Col	RHS 20x20x2	72	0
✓ Tr	RHS 20x20x2	48	1

Bar	Max [%]	RCS [%]	FB [%]	TFB [%]	LTB [%]	SB [%]	IA [%]
✓ B.837.1	94	94	-	-	78	-	79
✓ B.831.1	94	94	-	-	78	-	79
✓ B.843.1	94	94	-	-	78	-	79
✓ B.825.1	94	94	-	-	78	-	79

In Documentation the utilization results can be listed by design groups. In the status column the bars status can be **Real** or **Applied**. If the status is set to **Real** it means the originally defined cross-section (in Structure tab) is valid, otherwise the status called **Applied** and it means cross-section is not the original cross-section; and it is suggested by Auto Design or modified by Manual Design.

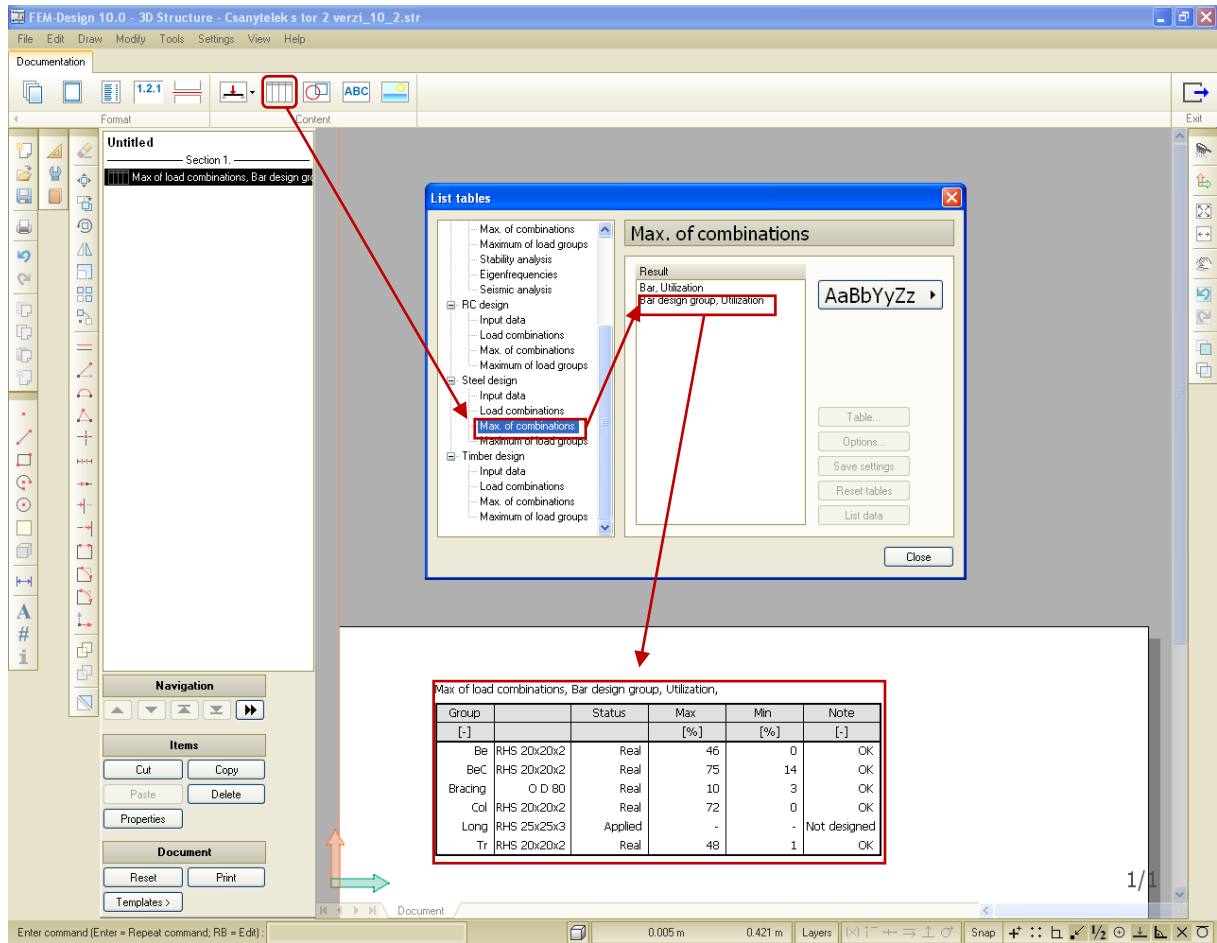

5.1 RC Design

Select direction and face is placed in separate panel. These icons are removed from auto and manual design palettes to main interface.

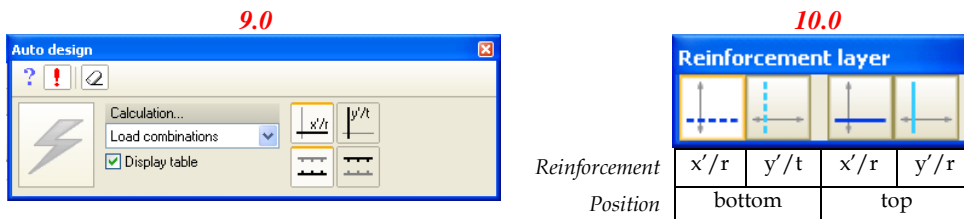

5.2 Timber Design

Timber bars with varying cross-section and apex zones can be and checked according to EC. Apex zone design checking is in "Bending in apex" and "Tension in apex" chapters of detailed result. Varying bar cross-section design checking is calculated with $k_{m,\alpha}$ parameter.

Lateral torsional buckling - 6.3.3

LC: 1 ($k_{mod} = 0.60$), $x = 457$ mm

$$I_{ef} = 1 / \left(\frac{12.5M_{max}}{2.5M_{max} + 3M_2 + 4M_3 + 3M_4} \right) \cdot l - 0.5h$$

$$I_{ef} = 1 / \left(\frac{12.5 \cdot 0.76}{2.5 \cdot 0.76 + 3 \cdot 0.76 + 4 \cdot 0.74 + 3 \cdot 0.73} \right) \cdot 0 - 0.5 \cdot 490 = 204 \text{ mm}$$

$$\sigma_{m,cr} = \frac{\pi \sqrt{E_{0.05} I_{ef}}}{l_{eff} W_{pl,y}} = \frac{3.14 \sqrt{6400 \cdot 3.263e+08 \cdot 400 \cdot 9.695e+08}}{204 \cdot 7.987e+06} = 1734.91 \text{ N/mm}^2 \quad (6.31)$$

$$\lambda_{rel,m} = \sqrt{\frac{f_{m,1,k}}{\sigma_{m,cr}}} = \sqrt{\frac{20.00}{1734.91}} = 0.107 \quad (6.30)$$

$$\lambda_{rel,m} \leq 0.75, \quad k_{crit} = 1.0 \quad (6.34)$$

$$K_{cr} = \frac{1}{\sqrt{1 + \left(\frac{f_{m,d}}{1.50 f_{v,d}} \tan \alpha \right)^2 + \left(\frac{f_{m,d}}{f_{e,90,d}} \tan^2 \alpha \right)^2}} = \frac{1}{\sqrt{1 + \left(\frac{9.23}{1.50 \cdot 1.02} \tan 0.63 \right)^2 + \left(\frac{9.23}{1.06} \tan^2 0.63 \right)^2}} = 0.16 \quad (6.40)$$

$$\frac{\sigma_{m,d}}{K_{cr} k_{cr} f_{m,1,d}} = \frac{0.09}{1.000 \cdot 0.16 \cdot 9.23} = 0.06 \leq 1 \quad (6.33) \text{ - OK}$$

$$\left(\frac{\sigma_{m,1,d}}{K_{cr} k_{cr} f_{m,1,d}} \right)^2 + \frac{\sigma_{e,0,d}}{K_{e,2} f_{e,0,d}} = \left(\frac{0.09}{1.000 \cdot 0.16 \cdot 9.23} \right)^2 + \frac{0.00}{0.782 \cdot 8.77} = 0.00 \leq 1 \quad (6.35) \text{ - OK}$$

Bending at apex - 6.4.3

LC: 1 ($k_{mod} = 0.60$), $x = 457$ mm

$\alpha_{ap} = 0.00$

$$k_1 = k_1 + k_2 \left(\frac{h_{ap}}{r} \right) + k_3 \left(\frac{h_{ap}}{r} \right)^2 + k_4 \left(\frac{h_{ap}}{r} \right)^3 = 1.00 + 0.35 \cdot \left(\frac{489.51}{0.00} \right) + 0.60 \cdot \left(\frac{489.51}{0.00} \right)^2 + 0.00 \cdot \left(\frac{489.51}{0.00} \right)^3 = 1.92 \quad (6.43)$$

$$\sigma_{m,d} = k_1 \frac{6M_{ap,d}}{bh_{ap}^2} = 1.92 \cdot \frac{6 \cdot 702807.73}{200.00 \cdot 489.51^2} = 0.17 \text{ N/mm}^2 \quad (6.42)$$

$$\frac{r_{m,d}}{r} = \frac{0.50}{0.03} = 16.67 < 240 \rightarrow k_r = 0.76 + 0.0001 \frac{r_{m,d}}{r} = 0.78 \quad (6.49)$$

$$\sigma_{m,d} = 0.17 \text{ N/mm}^2 \leq k_r f_{m,d} = 0.78 \cdot 9.23 = 7.17 \text{ N/mm}^2 \quad (6.41) \text{ - OK}$$

Tension at apex - 6.4.3

LC: 1 ($k_{mod} = 0.60$), $x = 457$ mm

$\alpha_{ap} = 0.00$

$$k_p = k_5 + k_6 \left(\frac{h_{ap}}{r} \right) + k_7 \left(\frac{h_{ap}}{r} \right)^2 = 0.00 + 0.25 \cdot \left(\frac{489.51}{0.00} \right) + 0.00 \cdot \left(\frac{489.51}{0.00} \right)^2 = 0.24 \quad (6.56)$$

$$\sigma_{t,90,d} = k_p \frac{6M_{ap,d}}{bh_{ap}^2} = 0.24 \cdot \frac{6 \cdot 702807.73}{200.00 \cdot 489.51^2} = 0.02 \text{ N/mm}^2 \quad (6.54)$$

$$k_{vol} = 1.0 \quad (6.51)$$

$$\frac{I_d}{I_{w,d}} + \frac{\sigma_{t,90,d}}{K_{d,d} k_{vol} f_{t,90,d}} = \frac{0.00}{1.02} + \frac{0.02}{1.40 \cdot 1.00 \cdot 0.23} = 0.07 \leq 1 \quad (6.53) \text{ - OK}$$

Summary

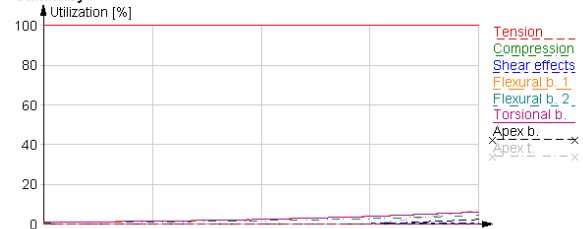

6 PREDESIGN

In PreDesign module it's possible to choose any Eurocode code, not only the British EC like in version 9.0.

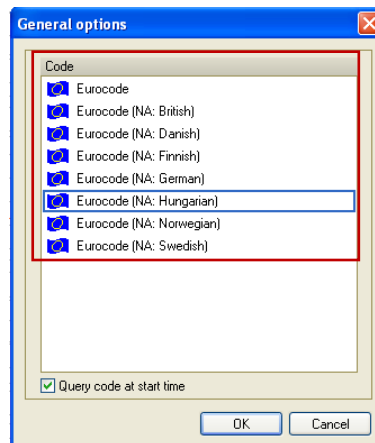

7 REALDWG

Totally new AutoCAD engine to Import and Export DWG and DXF files.

